

SNYDER

Equipment, Inc.

Storing, Rolling, Lifting since 1947



PRODUCT INFORMATION

B+P WALK, CURB AND WHEEL RAMPS

2946 Larimer St. Denver, CO 80205
303-295-1100 / 800-373-7693
FAX 303-295-2464
Email info@snyderequipment.com
www.snyderequipment.com

Aluminum Curb Ramps

- Our unique design contains no welds.
- Handle riveted to underside, doubles as the support leg allowing for a continuous solid surface with no cut outs.
- Aluminum quality at plastic prices.



Model No.	Width	Length	Weight	Thickness	Capacity
CRU2727	27"	27"	16#	3/16"	750#
CRU2618	26"	18"	9#	3/16"	750#
LCRU2727	27"	27"	11#	1/8"	500#
LCRU2618	26"	18"	6#	1/8"	500#



- Get heavy hand truck loads over curbs without straining your back.
- Lightweight, strong, durable curb ramps are ideal for anyone who uses a hand truck.
- Non-skid design provides secure footing.
- Cutout handle for easy handling.

Lower back injuries are a major factor in rising insurance costs. The curb ramp is designed to reduce lower

Aluminum Diamond Plate

Model No.	Width	Length	Weight	Thickness	Capacity
CR2618	26"	18"	10#	3/16"	750#
CR2727	27"	27"	17#	3/16"	750#
CR3030	30"	30"	21#	3/16"	750#

Aluminum with Smooth Deck and Non-Skid Strips

Model No.	Width	Length	Weight	Thickness	Capacity
NCR2727	27"	27"	17#	3/16"	750#
NCR3030	30"	30"	21#	3/16"	750#

Aluminum Walk Ramps



Our portable aluminum truck ramp is a low-cost double-safety ramp designed to speed loading and unloading, especially where facilities are limited or non-existent. Carrying this ramp in your truck speeds delivery by reducing time at each stop cutting costs at the same time.



NMFC 168720-S1 Class: 100

SPECIFICATIONS

TYPE	HT. RANGE* MIN --MAX (inches)		LGTH (ft.)	CAP (lbs.)	26" WIDE MODEL#-- (lbs)		28" WIDE MODEL#-- (lbs)		38" WIDE MODEL#-- (lbs)	
A	6	21	6	2,000	-	-	PR-2806-A	62	PR-3806-A	80
	6	25	7	1,800	-	-	PR-2807-A	72	PR-3807-A	92
	6	29	8	1,800	-	-	PR-2808-A	82	PR-3808-A	105
	6	33	9	1,650	-	-	PR-2809-A	92	PR-3809-A	117
	6	38	10	1,500	-	-	PR-2810-A	102	PR-3810-A	130
	6	46	12	1,400	-	-	PR-2812-A	122	PR-3812-A	155
	6	54	14	1,200	-	-	PR-2814-A	142	PR-3814-A	180
	6	62	16	1,000	-	-	PR-2816-A	162	PR-3816-A	205

F	6	23	6	2,000	PR-2606-F	61	PR-2806-F	62	PR-3806-F	80
	6	27	7	1,800	PR-2607-F	70	PR-2807-F	72	PR-3807-F	92
	6	31	8	1,800	PR-2608-F	80	PR-2808-F	82	PR-3808-F	105
	6	35	9	1,650	PR-2609-F	89	PR-2809-F	92	PR-3809-F	117
	6	40	10	1,500	PR-2610-F	99	PR-2810-F	102	PR-3810-F	130
	6	48	12	1,400	PR-2612-F	117	PR-2812-F	122	PR-3812-F	155
	6	56	14	1,200	PR-2614-F	137	PR-2814-F	142	PR-3814-F	180
	6	64	16	1,000	PR-2616-F	155	PR-2816-F	162	PR-3816-F	205

* Height Ranges based upon manageable 20°/36% grades for use with 2- and 4- wheel hand and floor trucks.

To better suit your needs, two types of ramps are available:

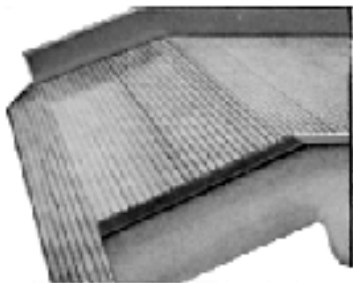

Type A - The level-off apron overlaps the truck bed. Standard safety chains are 18 inches.

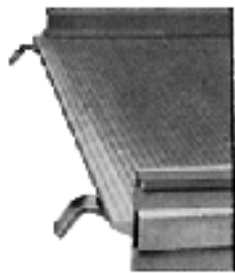

Type F - Steel hooks lock onto the truck bed providing flush-type direct entry.

Aluminum Wheel Ramps

Portable Risers Raise Vehicles Closer to Dock Height for Efficient Loading

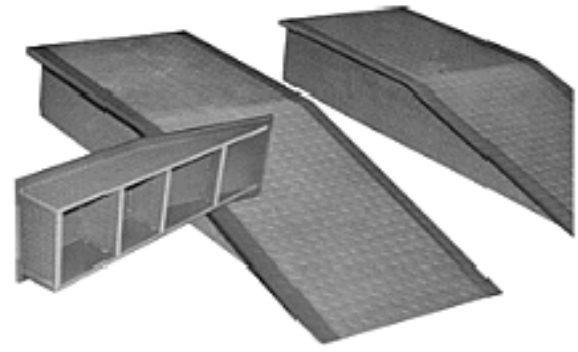

How to Select Your Ramp

Ramp selection is based on the following three items:

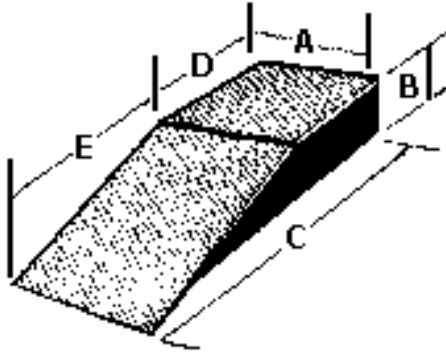

A-Width: Based on the maximum wheel width of your largest vehicle. For double wheel vehicles, choose the 24" width and use the ramp at the inside wheel location.

B-Height: Determined by the following formula - Dock Height plus 2" minus Truck Bed Height=B-Height.

C-Length: The longer the ramp, the less the incline angle. Choose a length with an incline angle that your loaded vehicles can

negotiate easily.

Without Wheel Ramp

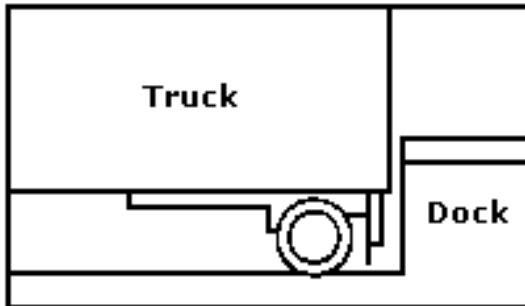

With Wheel Ramp

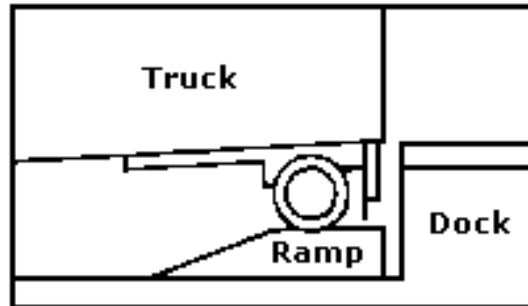

Specifications

Capacity for all Models - 12,000 Lbs. Per Ramp

B

C

D

E

A

A

Height (In.)	Length (In.)			18" Wide		24" Wide	
	Overall	Level	Incline	Model No.	Weight (Lbs.)	Model No.	Weight (Lbs.)
6	48	30	18	PR-18-6-48	64	PR-24-6-48	79
	60	42	18	PR-18-6-60	77	PR-24-6-60	94
	102	84	18	PR-18-6-102	126	PR-24-6-102	145
8	54	30	24	PR-18-8-54	78	PR-24-8-54	94
	60	36	24	PR-18-8-60	85	PR-24-8-60	103
	10	84	24	PR-18-8-108	147	PR-24-8-108	169
10	60	30	30	PR-18-10-60	95	PR-24-10-60	115
	66	36	30	PR-18-10-66	102	PR-24-10-66	124
	72	42	30	PR-18-10-72	111	PR-24-10-72	133
	114	84	30	PR-18-10-114	166	PR-24-10-114	188
12	72	36	36	PR-18-12-72	125	PR-24-12-72	143
	78	42	36	PR-18-12-78	137	PR-24-12-78	153
	120	84	36	PR-18-12-120	188	PR-24-12-120	213

Other sizes are available.