



SNYDER



Equipment, Inc.

Storing, Rolling, Lifting since 1947

PRODUCT INFORMATION

LYON WORK BENCHES

2946 Larimer St. Denver, CO 80205

303-295-1100 / 800-373-7693

FAX 303-295-2464

Email info@snyderequipment.com

www.snyderequipment.com

Lyon Work Stations

Workspace Furniture To Meet Every Need!

Use the Selection Guide below to identify the type of bench that meets your needs exactly. Then, add the appropriate ergonomic chairs (pp. 6-16) and Sky-Wal II™ above the bench ergonomic accessories (pp. 18-21) to create work stations that maximize productivity and reduce CTD (Cumulative Trauma Disorders) and RSI (Repetitive Stress Injuries).



Work Bench Selection Guide



TOP	Adjustable Leg Benches PP. 40-41	Flared Leg Benches PP. 42-43	Assembly Benches PP. 44-45	Ergo Benches PP. 22-23	Slide-Bolt Bench PP. 51	Cabinet Benches PP. 50	Modular Benches PP. 48-49	Electronic Benches PP. 46-47
12-Gauge Steel								
	Heavy duty maintenance; manual height adjustability	Heavy duty maintenance; maximum stability	Heavy duty maintenance; manual height adjustment	Light duty maintenance; maximum height adjustability for multi-shift operations	Heavy duty maintenance; manual height adjustability	Service counter; Heavy duty maintenance; maximum storage capacity	Heavy duty maintenance; Maximum storage flexibility	N/A
Pressed Wood-Over Steel								
	Heavy duty assembly; manual height adjustability	Heavy duty assembly; maximum stability	Heavy duty maintenance; manual height adjustment	Medium duty assembly; Maximum height adjustability for multi-shift operations	Heavy duty assembly; manual height adjustability	Heavy duty assembly (standing); maximum storage capacity	Medium duty assembly; (seated) maximum storage flexibility	N/A
Laminated Hardwood								
	Precision assembly and repair; manual height adjustability	Precision assembly and repair; maximum stability	Precision assembly and repair; manual height adjustment	Precision assembly and repair; maximum height adjustability for multi-shift operations	Precision assembly and repair; manual height adjustability	Service counter; Precision assembly, repair; maximum storage capacity	Precision assembly, repair; maximum storage flexibility	N/A
Pressed Wood-Over Wood								
	All-purpose work surface; manual height adjustability	All-purpose work surface; maximum stability	All-purpose work surface; manual height adjustment	All-purpose work surface; maximum height adjustability for multi-shift operations	All-purpose work surface; manual height adjustability	All-purpose work surface; maximum storage capacity	All-purpose work surface; maximum storage flexibility	N/A
Plastic Laminate – 180° Soft Front Edge								
	Light assembly, packaging, office, school, commercial use. Manual height adjustment	Light assembly, packaging, maximum stability	Light assembly, packaging, office, school, commercial use. Manual height adjustment	Light assembly, packaging, maximum height adjustability for multi-shift operations	Light assembly, packaging, office, school, commercial use. Manual height adjustment	Light assembly, packaging, (standing) maximum storage capacity	Light assembly, (seated); maximum storage flexibility	N/A
Super Comp Top – 180° Soft Front Edge								
	Abuse resistant surface for assembly, repair, manual height adjustability	Abuse resistant surface for assembly, repair, maximum stability	Abuse resistant surface for assembly, repair, max. stability, manual height adjustment	Abuse resistant surface for assembly, repair, max. height adjustability for multi-shift operations	Abuse resistant surface for assembly, repair, manual height adjustability	Abuse resistant surface for assembly, repair, maximum storage capacity	Abuse resistant surface for assembly, repair, maximum storage flexibility	N/A
Laminated Hardwood – 180° Soft Front Edge								
	Same as Laminated Hardwood Top above, plus 180° soft front edge	Same as Laminated Hardwood Top above, plus 180° soft front edge	Same as Laminated Hardwood Top above, plus 180° soft front edge	Same as Laminated Hardwood Top above, plus 180° soft front edge	Same as Laminated Hardwood Top above, plus 180° soft front edge	Same as Laminated Hardwood Top above, plus 180° soft front edge	Same as Laminated Hardwood Top above, plus 180° soft front edge	N/A
ESD – 180° Soft Front Edge								
	Assembly of electronic parts, components. Resistivity of 10 ⁹ to 10 ¹⁰ OHMS, 100 volts	N/A	N/A	Assembly of electronic parts, components. Resistivity of 10 ⁹ to 10 ¹⁰ OHMS, 100 volts	N/A	N/A	N/A	Assembly of electronic parts, components. Resistivity of 10 ⁹ to 10 ¹⁰ OHMS, per square foot.
Graphite Composite – Comfort Edge								
	Solvent resistant, medium duty work surface. Manual height adjustment	Medium duty assembly, packaging; maximum stability	Medium duty assembly, packaging; Manual height adjustment	Medium duty assembly, packaging; maximum height adjustment for multi-shift operations	Solvent resistant, medium duty work surface. Manual height adjustment	N/A	N/A	N/A

Versatile, Adjustable-Leg Work Benches ...

- Sturdy steel channel legs, adjust top from 27¼" to 36¼" high, (*add for top thickness, see chart below*) provide firm support for top selections listed below.
- Welded steel cross members add strength and durability.
- Optional leg levelers (pictured at right) afford easy adaption to uneven flooring for stability.
- Electrical knockouts on each leg offer space for duplex outlet boxes (not included) and subsequent electrical hookup.
- Each bench selection is available in your choice of eight different tops, as listed below.
- See detailed description and application for each top on page 54.
- Accessories on page 55.

Adjustable Legs with Optional Leg Levelers No. NF2757

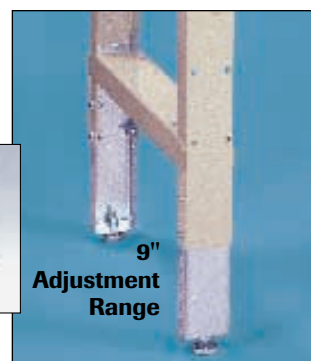

Work Bench with Stringer

Work Bench with Stringer & Drawer

48" w x 28" d					60" w x 28" d					60" w x 34" d					72" w x 28" d					72" w x 34" d					TOPS																												
12-Gauge Steel																						2462A	2463A	2464A	2465A	2466A																											
2468A	2502A	2503A	2504A	2505A												Pressed Wood Over Steel																						N/A	2469A	2470A	2471A	2472A											
N/A	2530A	2531A	2532A	2533A												Laminated Hardwood																						N/A	2506A	2507A	2508A	2509A											
N/A	2540A	2541A	2542A	2543A												Pressed Wood Over Wood																						N/A	2514A	2515A	2516A	2517A											
N/A	2444A	2445A	2446A	2447A												Plastic Laminate – 180° Soft Front Edge																						N/A	2518A	2519A	2520A	2521A											
N/A	2476A	2477A	2478A	2479A												Super Comp Top – 180° Soft Front Edge																						N/A	2544A	2545A	2546A	2547A											
N/A	2488A	2489A	2490A	2491A												Laminated Hardwood – 180° Soft Front Edge																						N/A	2577A	2578A	2579A	2580A											
N/A	2565A	2566A	2567A	2568A												Graphite Composite – Comfort Edge																						N/A	2411A	N/A	N/A	N/A											
N/A	2410A	N/A	N/A	N/A																							N/A	2411A	N/A	N/A	N/A																						

Put Tasks At The Right Work Heights!

Perfect-Fit Bench Drawers

- Perfect-fit Bench Drawers are 9" deep.
- Easily accommodate aerosol cans.
- Lunch totes, purses, manuals, directories – and all those other things that just don't fit handily in standard size drawers.



COLOR INFORMATION
choose from the following

in stock **Dove Gray**
Add Prefix **DD** to Cat. No.
All steel components

in stock **Putty**
Add Prefix **PP** to Cat. No.
All steel components

WedgeWood Blue
Add Prefix **BB** to Cat. No.
All steel components

Ash
Add Prefix **AA** to Cat. No.
All steel components

*NOTE: Plastic Laminate Tops are only available in Dove Gray or Putty. Ash and Wedgewood Blue benches will come with Putty tops only.

Accessories and Related Products

- Sky-Wal II™ above-the-top ergonomic accessories, pages 18-21.
- Accessories, page 55.
- Additional Benches, pages 22-23, 42-43, 44-54.



Work Bench with Stringer & Shelf

Work Bench with Stringer, Drawer & Shelf

48" w x 28" d	60" w x 28" d	60" w x 34" d	72" w x 28" d	72" w x 34" d	TOPS	48" w x 28" d	60" w x 28" d	60" w x 34" d	72" w x 28" d	72" w x 34" d
12-Gauge Steel										
2474A	2522A	2523A	2524A	2525A	 1 3/4" Thick	2400A	2401A	2402A	2403A	2404A
Pressed Wood Over Steel										
N/A	2534A	2535A	2536A	2537A	 1 3/4" Thick	N/A	2405A	2406A	2407A	2408A
Laminated Hardwood										
N/A	2550A	2551A	2552A	2553A	 1 3/4" Thick	N/A	2427A	2428A	2429A	2430A
Pressed Wood Over Wood										
N/A	2454A	2455A	2456A	2457A	 1 3/4" Thick	N/A	2431A	2432A	2433A	2434A
Plastic Laminate – 180° Soft Front Edge										
N/A	2480A	2481A	2482A	2483A	 1" Thick	N/A	2435A	2436A	2437A	2438A
Super Comp Top – 180° Soft Front Edge										
N/A	2492A	2493A	2494A	2495A	 1 3/4" Thick	N/A	2439A	2440A	2441A	2442A
Laminated Hardwood – 180° Soft Front Edge										
N/A	2569A	2570A	2571A	2572A	 1 3/4" Thick	N/A	2448A	2449A	2450A	2451A
Graphite Composite – Comfort Edge										
N/A	2420A	N/A	N/A	N/A	 1 1/2" Thick	N/A	2421A	N/A	N/A	N/A

Pre-Engineered Steel Leg Work Benches ...

- Leg Height is 32 1/4" high, add for top thickness.
- Heavy channel steel flared legs provide sturdy base for a variety of bench work tasks.
- Steel cross members welded between each upright add strength and rigidity.
- Base plates punched for floor bolts provide 24 square inch floor bearing surface per leg.
- Choose from eight different work surfaces (below) described on page 54.

Flared Legs



No. 2510 shown in Putty with 2788 Drawer, 2628 Shelf Riser, 2662 Outlet Strip and 2602 Back and End Stops. See page 55 for Accessory information.



Leg Height 32 1/4"
Add for Top Height

Work Bench with Stringer

Work Bench with Stringer & "Perfect-Fit" Drawer

48" w x 28" d					60" w x 28" d					60" w x 34" d					72" w x 28" d					72" w x 34" d				
TOPS																								
12-Gauge Steel																								
1 3/4" Thick																								
2468	2502	2503	2504	2505		2462	2463	2464	2465	2466														
Pressed Wood Over Steel																								
1 3/4" Thick																								
N/A	2530	2531	2532	2533		N/A	2469	2470	2471	2472														
Laminated Hardwood																								
1 3/4" Thick																								
N/A	2540	2541	2542	2543		N/A	2506	2507	2508	2509														
Pressed Wood Over Wood																								
1 3/4" Thick																								
N/A	2444	2445	2446	2447		N/A	2514	2515	2516	2517														
Plastic Laminate — 180° Soft Front Edge																								
1 3/8" Thick																								
N/A	2476	2477	2478	2479		N/A	2518	2519	2520	2521														
Super Comp Top — 180° Soft Front Edge																								
1 3/4" Thick																								
N/A	2488	2489	2490	2491		N/A	2544	2545	2546	2547														
Laminated Hardwood — 180° Soft Front Edge																								
1 3/4" Thick																								
N/A	2565	2566	2567	2568		N/A	2577	2578	2579	2580														
Graphite Composite — Comfort Edge																								
1 1/2" Thick																								
N/A	2410	N/A	N/A	N/A		N/A	2411	N/A	N/A	N/A														

Flared Footprint Maximizes Stability!

Perfect-Fit Bench Drawers

- Perfect-fit Bench Drawers are 9" deep.
- Easily accommodate aerosol cans.
- Lunch totes, purses, manuals, directories – and all those other things that just don't fit handily in standard size drawers.



COLOR INFORMATION, choose from the following

- in stock** **Dove Gray**
Add Prefix **DD** to Cat. No.
All steel components
- in stock** **Putty**
Add Prefix **PP** to Cat. No.
All steel components
- WedgeWood Blue**
Add Prefix **BB** to Cat. No.
All steel components
- Ash**
Add Prefix **AA** to Cat. No.
All steel components

*NOTE: Plastic Laminate Tops are only available in Dove Gray or Putty. Ash and Wedgewood Blue benches will come with Putty tops only.

Accessories and Related Products

- Sky-Wal II™ above-the-top ergonomic accessories, pages 18-21.
- Accessories, page 55.
- Additional Benches, pages 22-23, 40-41, 44-54.



Work Bench with Stringer & Shelf

Work Bench with Stringer, "Perfect-Fit" Drawer & Shelf

48" w x 28" d	60" w x 28" d	60" w x 34" d	72" w x 28" d	72" w x 34" d	TOPS	48" w x 28" d	60" w x 28" d	60" w x 34" d	72" w x 28" d	72" w x 34" d
12-Gauge Steel										
2474	2522	2523	2524	2525	 1 3/4" Thick	2400	2401	2402	2403	2404
Pressed Wood Over Steel										
N/A	2534	2535	2536	2537	 1 3/4" Thick	N/A	2405	2406	2407	2408
Laminated Hardwood										
N/A	2550	2551	2552	2553	 1 3/4" Thick	N/A	2427	2428	2429	2430
Pressed Wood Over Wood										
N/A	2454	2455	2456	2457	 1 3/4" Thick	N/A	2431	2432	2433	2434
Plastic Laminate – 180° Soft Front Edge										
N/A	2480	2481	2482	2483	 1 5/8" Thick	N/A	2435	2436	2437	2438
Super Comp Top – 180° Soft Front Edge										
N/A	2492	2493	2494	2495	 1 3/4" Thick	N/A	2439	2440	2441	2442
Laminated Hardwood – 180° Soft Front Edge										
N/A	2569	2570	2571	2572	 1 3/4" Thick	N/A	2448	2449	2450	2451
Graphite Composite – Comfort Edge										
N/A	2420	N/A	N/A	N/A	 1 1/2" Thick	N/A	2421	N/A	N/A	N/A

Pre-Engineered Assembly Work Stations ...

- Assembly Work Stations feature adjustable steel channel-legs with leg levelers and plastic laminate tops.
- These versatile work stations are ideally suited for all types of assembly operations, as well as office, school and commercial use.
- Bench heights adjust 27¼" to 36¼" (add 1½" for top).
- Plastic laminate tops have 180° soft front edge for worker comfort.

COLOR INFORMATION, for Assembly Work Stations

WedgeWood Blue
Main components consisting of legs, stringer & shelf, drawer housing and riser supports.

Putty
By adding prefix **PP** to Cat. No., top, drawer front & instrument shelf top will be putty (main components will be wedgeWood blue).

Dove Gray
By adding prefix **DD** to Cat. No., top, drawer front & instrument shelf top will be Dove Gray (main components will be wedgeWood blue).

NOTE: Other colors available. Contact customer service



Pre-engineered work station shown with optional accessories.

How to order

Start with pre-engineered units, add accessories (at right) to fit the tasks. Electrical knockouts on each leg accommodate duplex outlets (order separately, on opposite page).



Work Station with Stringer

Work Station with Stringer and Utility Drawer

				TOPS				
60" w x 28" d	60" w x 34" d	72" w x 28" d	72" w x 34" d	Plastic Laminate				
75518	75524	75618	75624		75538	75544	75638	75644



COLOR INFORMATION, at the bottom of page 45

All-Welded Workbench

All-welded heavy-duty construction is ideal for heavy-duty maintenance and production work.

- Easy to clean and maintain for long service life.
- Sturdy flared legs provide added stability.
- Work bench includes shelf and stringer.
- Bench also accepts optional accessories.
- Dove Gray finish.

No. 2522W
60" w x 28" d x 34" h

(A) Mobile Workbench

Mobility is the key to doing bench work where it's needed – when it's needed. Saving time and effort has built this unit's reputation with maintenance people, millwrights, mechanics and supervisors of mobile production lines.

- Bench wheels are stationary, 3" in diameter.
- Wheelbarrow type handles slide out of the way under the bench top.
- Comes complete as shown.

No. 2560 – 72" w x 28" d x 34" h
No. 2562 – Extra casters for 2560

For Light Assembly and Production Tasks.

Optional Accessories For Assembly Work Stations



Instrument Shelf

- Add storage space on 15" deep plastic laminate shelf with 180° soft front edge.
 - Electrical knockouts on shelf supports for duplex outlets (order separately).
 - Back brace flange holds plastic bins.
- No. 78505** – Overall: 60"w x 15"d x 19½"h
No. 78506 – Overall: 72"w x 15"d x 19½"h



Electrical kit

- For Instrument Shelf.*
- Includes four duplex outlets, two for each shelf support.
- No. 78110**

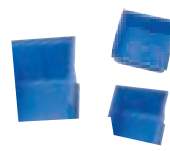

Blue Plastic Bins

- Impervious to most solvents, corrosives.
 - Hang securely on back brace of Instrument Shelf.
- No. 78203**
4"w x 4"d x 2"h, 32 cu. in.
No. 78206
4"w x 6½"d x 3"h, 78 cu. in.
No. 78209
6"w x 9½"d x 5"h, 285 cu. in.

Utility Drawer

- Attach to either side of bench, or stack.
 - Includes sliding drawer tray, and padlock attachment.
 - Drawer glides inside case on ball bearing rollers. 21¾"w x 20"d x 6¾"h.
 - Wedgewood Blue case.
- No. BP78100** – Putty Drawer Front
No. BD78100 – Dove Gray Drawer Front
No. 7037 – Grooved Key Lock
Modesty Panel (NOT SHOWN)
- 20-gauge steel.
 - Wedgewood Blue only.
- No. 78135** – for 60"w benches
No. 78136 – for 72"w benches



Work Station with Stringer and Shelf

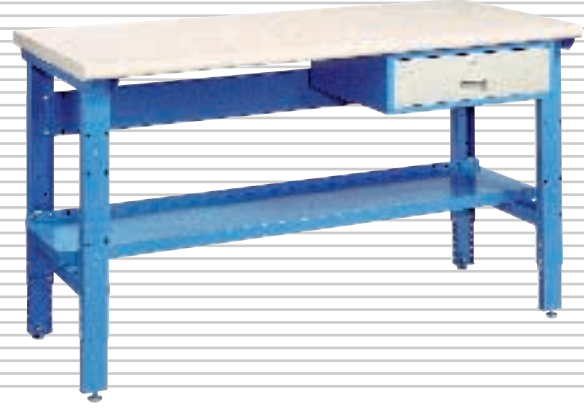

Work Station with Stringer, Shelf and Utility Drawer



60" w x 28" d	60" w x 34" d	72" w x 28" d	72" w x 34" d	TOPS				60" w x 28" d	60" w x 34" d	72" w x 28" d	72" w x 34" d
				Plastic Laminate							
				1½" Thick							
75528	75534	75628	75634		75548	75554	75648	75654			

(B) Roll Around Workbench

Portable workbench saves time and effort for maintenance people, millwrights, mechanics and workers on mobile production lines.

- Features two 3" swivel casters with side brakes and two 3" rigid casters for maximum mobility and lock in place stability.
- Comes complete with top, shelf, stringer, back and end stops, and legs.

- No. 2563** – 60" w x 28" d x 34" h
No. 2564 – 72" w x 28" d x 34" h

(B)

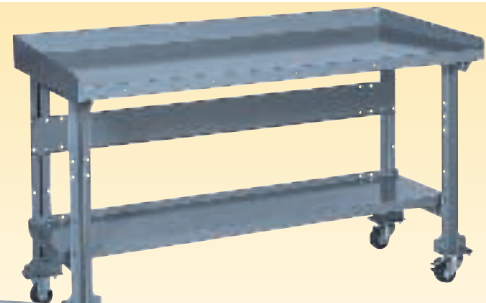

(A)

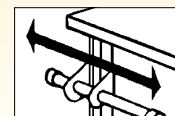

Handle slides under bench top when not in use

COLOR INFORMATION, choose from the following

in stock	Dove Gray - in stock Add Prefix DD to Cat. No. All steel components	Wedgewood Blue Add Prefix BB to Cat. No. All steel components
	Putty Add Prefix PP to Cat. No. All steel components	Ash Add Prefix AA to Cat. No. All steel components

Electronic Assembly Work Stations ...

- Static-dissipative work benches feature chip-resistant, ESD plastic laminate tops with 180° soft front edge and 10⁶ to 10⁹ OHMS, 100 volts.
- Start with pre-engineered work bench selections shown below, then add accessories to create the work stations needed for your specific application.
- Adjustable bench-legs include levelers, provide bench heights from 27¼" to 36¼" (add 1⅝" for top).
- Electrical knockout on each leg. Utility drawer includes sliding tray and padlock attachment.

COLOR INFORMATION, for Assembly Work Stations

- WedgeWood Blue**
Main components consisting of legs, stringer & shelf, drawer housing and riser supports.
- Putty**
By adding prefix **PP** to Cat. No., top, drawer front & instrument shelf top will be putty (main components will be wedgeWood blue).
- Dove Gray**
By adding prefix **DD** to Cat. No., top, drawer front & instrument shelf top will be Dove Gray (main components will be wedgeWood blue).

NOTE: Other colors available. Contact customer service



Pre-engineered work station shown with new ESD Sit-Stand stool and other accessories.



ESD Work Station with Stringer

ESD Work Station with Stringer and Utility Drawer

60"w x 28"d	60"w x 34"d	72"w x 28"d	72"w x 34"d	TOPS		60"w x 28"d	60"w x 34"d	72"w x 28"d	72"w x 34"d
				Static Dissipative (ESD)					
				1⅝" Thick					
77518	77524	77618	77624			77538	77544	77638	77644

Optional Accessories for ESD Assembly Work Stations

Related Product

- ESD Sit Stand Stools, page 9.



ESD Instrument Shelf

Add storage space on 15" deep plastic laminate shelf with 180° soft front edge and 10⁶ to 10⁹ OHMS, 100 volts. Electrical knockouts on shelf supports for duplex outlets (order separately). Back brace flange holds plastic bins.

No. 78705 – Overall: 60"w x 15"d x 19¼"h

No. 78706 – Overall: 72"w x 15"d x 19¼"h



Electrical Outlet

For Instrument Shelf. Includes four duplex outlets, two for each shelf support.

No. 78110

Utility Drawer

Attach to either side of bench, or stack. Includes sliding drawer tray, and padlock attachment. Drawer glides inside case on ball bearing rollers.

No. 78100 – 21¼"w x 20"d x 6¾"h

No. 7037 – Grooved Key Lock

Add **BP** for putty drawer.

Add **BD** for dove gray drawer.

Modesty Panel (NOT SHOWN)

20-gauge steel. Wedgewood Blue only. 6½" high.

No. 78135 – for 60"w benches

No. 78136 – for 72"w benches

Static Dissipative and Adjustable!

Ergonomic ESD Seating

- Discharge static electricity through integrated circuit ESD chairs, ergonomically designed to maximize worker comfort, promote good posture and reduce musculoskeletal disorders.
- Seat heights adjust 19" to 27" with automatic 8" adjustment while seated.
- Waterfall seat fronts ease pressure behind knees.
- Contoured tilt backs provide lumbar support.
- Five-leg base with circular footring.
- Gray fabric seats and backs are Scotch-guarded.

(A) Deluxe ESD Chair

Large 2½" thick molded foam seat 18"w x 18"d with 16"w x 15"d backrest. Single ALLMATIK control adjusts seat tilt 8°, backrest 20°. Backrest height adjusts 4".

No. 2056

Options

- No. 2068** – Loop armrest for 2056
- No. 2070** – Open armrest for 2056
- No. 2071** – Hard floor conductive casters



See page 14 for additional information.

(B) ESD Chair

Padded foam seat 2" thick, 18"w x 17"d; with 15"w x 11" backrest. Backrest adjusts 3" height and depth.

No. 2054



ESD Work Station with Stringer and Shelf

ESD Work Station with Stringer, Shelf and Utility Drawer

60"w x 28"d	60"w x 34"d	72"w x 28"d	72"w x 34"d	TOPS				60"w x 28"d	60"w x 34"d	72"w x 28"d	72"w x 34"d
Static Dissipative (ESD)											
				1½" Thick							
77528	77534	77628	77634		77548	77554	77648	77654			

Electrical and Grounding Options for ESD Assembly Work Stations



Outlet Strip With Surge Protector

Protect equipment from power surges or electrical noise damage. Six outlet lighted power switch and surge suppressor indicator, 15 amp resettable circuit breaker, 40 db noise filter, 18,000 AMP maximum surge suppression. Response time: (-5) nano seconds.

No. 78107



Wrist Ground System

Provides common ground for two wrist straps. Mount under top. 10 foot cord. Black only.

No. 78120



Adjustable Wrist Straps

For use with Ground System at left. Provides permanent ground path. One size fits all. 10 foot ground cord.

No. 78121



ESD Plastic bins

Made of conductive material. Impervious to most solvents, corrosives. Hang securely on back brace of Instrument Shelf. Black only.

- No. 78213** – 4"w x 4"d x 2"h
32 cu. in.
- No. 78216** – 4"w x 6½"d x 3"h
78 cu. in.
- No. 78219** – 6"w x 9½"d x 5"h
285 cu. in.

Conductive Floor Mat (SEE PHOTO ON FACING PAGE)

Removes static charge from personnel approaching work station. 4'w x 6'd. Black only.

No. 78125

Pre-Engineered Modular Work Stations ...

- Versatile combinations include both cabinet pedestals and drawer pedestals with smooth gliding ball bearing rollers and removable sliding trays.
- Each unit stands 32 1/4" high without top. Add for top thickness (see chart below).
- Bases on cabinets can be removed to lower work height to 28 3/4" for use as a desk in the factory.
- Units will accept 28" deep back and end stops and shelf risers (page 55).
- Drawers are equipped with padlock hasp (padlock not included). Order built-in grooved key lock separately. (See page 55).
- For top descriptions, see page 54.

"PERFECT-FIT" Bench Drawers

- 9" deep to easily accommodate aerosol cans, lunch totes, purses, manuals, directories – and all those other things that just don't fit handily in standard size drawers.

No. 2794

Low Profile Drawers

- 6 3/4" high (15 3/4" w x 20" d) to hold small tools, parts and other accessories.
- Removable sliding trays included.

No. 2788



Panel Leg Modular Work Stations

Includes top, three "Perfect-Fit" drawers, 5 1/4" h base, panel leg and footrest.

"Perfect-Fit" Drawer/Cabinet Modular Work Stations

Includes top, three "Perfect-Fit" drawers, two 5 1/4" h bases, one cabinet with adjustable shelf (cabinet can be inverted).

COLOR INFORMATION, choose from the following

- in stock** Dove Gray
Add Prefix **DD**
to Cat. No.
- in stock** Putty
Add Prefix **PP**
to Cat. No.
- Wedgewood Blue
Add Prefix **BB**
to Cat. No.
- Ash
Add Prefix **AA**
to Cat. No.

60" w x 28" d	72" w x 28" d	TOPS		60" w x 28" d	72" w x 28" d
12-Gauge Steel					
1 1/4" Thick					
2901	2903			2905	2906
Pressed Wood Over Steel					
1 1/4" Thick					
2907	2912			2913	2918
Laminated Hardwood					
1 1/4" Thick					
2919	2923			2924	2925
Pressed Wood Over Wood					
1 1/4" Thick					
2927	2929			2930	2931
Plastic Laminate – 180° Soft Front Edge					
1 1/8" Thick					
2951	2955			2957	2961
Super Comp Top – 180° Soft Front Edge					
1 1/4" Thick					
2963	2967			2972	2973
Laminated Hardwood – 180° Soft Front Edge					
1 1/4" Thick					
2978	2979			2983	2984

or Components For Custom Designs

- Engineer 32³/₄" high Modular Work Stations with these steel components. See page 55 for drawer descriptions.
- Order tops described on page 54.
- Cabinet pedestal contains one adjustable shelf and can be inverted for use on left or right.

Numerical "stacking values" (1-7) must add up to seven on each side of the desk to support top selection from page 54.

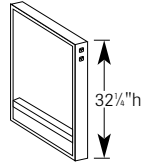

No. 2800
Panel leg (7)

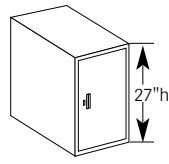

No. 2991
Cabinet (6)

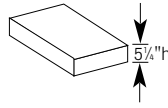

No. 2994
Base (1)

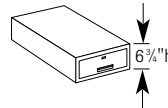

No. 2788
Drawer (1.5)

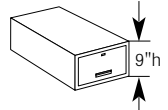

No. 2794
Drawers (2)

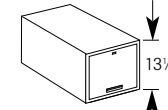

No. 2790
Drawers (3)

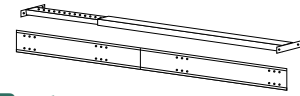

Foot Rests (0)

- No. 2801** – Pedestal – Panel – 41⁵/₃₂" – 62¹⁹/₃₂"
- No. 2802** – Pedestal/Pedestal – 39⁵/₃₂" – 59¹/₂"
- No. 2803** – Pedestal – Panel – 54" – 69"
- No. 2804** – Pedestal/Pedestal – 28³/₈" Fixed

Lock Kits (0)

- No. NF7037** – Fits No. 2788, 2789, 2794 & 2790 drawers.

All items shown above are 15¹/₄"w x 20"d except Panel Legs which are 3"w x 20"d.



"Perfect-Fit" Drawer Modular Work Stations

Includes top, six "Perfect-Fit" drawers, and two 5¹/₄"h bases.

Utility Drawer Modular Work Stations

Includes top, eight Low Profile Drawers, and two 5¹/₄"h bases.

60"w x 28"d	72"w x 28"d	TOPS	
		12-Gauge Steel	
2933	2935	 1 ³ / ₄ " Thick	2932 2934
		Pressed Wood Over Steel	
2936	2937	 1 ³ / ₄ " Thick	2938 2940
		Laminated Hardwood	
2942	2943	 1 ³ / ₄ " Thick	2944 2946
		Pressed Wood Over Wood	
2948	2949	 1 ³ / ₄ " Thick	2950 2952
		Plastic Laminate – 180° Soft Front Edge	
2953	2954	 1 ³ / ₄ " Thick	2956 2958
		Super Comp Top – 180° Soft Front Edge	
2959	2960	 1 ³ / ₄ " Thick	2945 2947
		Laminated Hardwood – 180° Soft Front Edge	
2965	2966	 1 ³ / ₄ " Thick	2939 2941

COLOR INFORMATION, choose from the following

- in stock** Dove Gray
Add Prefix **DD**
to Cat. No.
- in stock** Putty
Add Prefix **PP**
to Cat. No.
- WedgeWood Blue
Add Prefix **BB**
to Cat. No.
- Ash
Add Prefix **AA**
to Cat. No.

Related Products





- Accessories, page 55.
- Additional Benches, pages 39-47, 50-54.

Pre-Engineered Cabinet Work Benches

Maximize Under-Bench Storage!

- Ideal for garages, tool cribs, mailrooms and other locations where an enclosed type bench is desired. Cabinet work benches also make great service counters! Install two or more units side by side to define work areas.
- Each units normal height is 34" high.
- Pre-engineered unit includes a center shelf adjustable on 1 1/2" centers.
- For top descriptions, see page 54.

COLOR INFORMATION, choose from the following

 Dove Gray Add Prefix DD to Cat. No. <i>Main bench</i>	 Wedgewood Blue Add Prefix BB to Cat. No. <i>Main bench</i>
 Putty Add Prefix PP to Cat. No. <i>Main bench</i>	 Ash Add Prefix AA to Cat. No. <i>Main bench</i>

Note: Cabinet work benches are not compatible with Sky-Wall II™ components.

Components and Accessories For Cabinet Work Benches

Cabinet Bench Without Top

No. 2854 – 60" w x 25" d x 32 1/4" h

No. 2856 – 72" w x 25" d x 32 1/4" h

Extra Shelves

No. 2866 – for 60" w bench

No. 2868 – for 72" w bench

Sliding Doors Only

No. 2860 – for 60" w bench

No. 2861 – for 72" w bench



Low Profile Drawers

Add up to two for more lockable storage. Great for tools, parts, etc. Removable sliding tray included.

No. 2788 – 15 1/2" w x 20" d x 6 1/4" h

No. 7037 – Grooved Key Lock for 2788 drawer

* Keylock and Two Keys Included.



Cabinet Work Bench with one Shelf



Cabinet Work Bench with Sliding Doors*



Cabinet Work Bench with one Shelf and Drawer



Cabinet Work Bench with Sliding Doors* and Drawer

60" w x 28" d	72" w x 28" d	TOPS		60" w x 28" d	72" w x 28" d
		12-Gauge Steel			
2832	2834		1 3/4" Thick	2833	2835
		Pressed Wood Over Steel			
2838	2840		1 3/4" Thick	2839	2841
		Laminated Hardwood			
2844	2846		1 3/4" Thick	2845	2847
		Pressed Wood Over Wood			
2850	2852		1 3/4" Thick	2851	2853
		Plastic Laminate – 180° Soft Front Edge			
2870	2872		1 5/8" Thick	2871	2873
		Super Comp Top – 180° Soft Front Edge			
2890	2892		1 3/4" Thick	2891	2895
		Laminated Hardwood – 180° Soft Front Edge			
2880	2882		1 3/4" Thick	2881	2883

60" w x 28" d	72" w x 28" d	TOPS		60" w x 28" d	72" w x 28" d
		12-Gauge Steel			
2830	2831		1 3/4" Thick	2836	2837
		Pressed Wood Over Steel			
2842	2843		1 3/4" Thick	2848	2849
		Laminated Hardwood			
2857	2858		1 3/4" Thick	2862	2863
		Pressed Wood Over Wood			
2864	2865		1 3/4" Thick	2874	2875
		Plastic Laminate – 180° Soft Front Edge			
2876	2877		1 5/8" Thick	2878	2879
		Super Comp Top – 180° Soft Front Edge			
2884	2885		1 3/4" Thick	2886	2887
		Laminated Hardwood – 180° Soft Front Edge			
2888	2889		1 3/4" Thick	2893	2894

Customize your cabinet bench further with universal work bench accessories!

Since Lyon work benches share common tops, you can further customize your bench by adding more accessories such as Back & End Stops, Risers, Pick Racks, and Electrical Outlet Strips. See page 55 for more information on accessories.



Adjustable Slide Bolt Leg Benches ... With a Full 8" Adjustment Range!

- Putting tasks at the correct heights improves worker comfort, increases productivity.
- Lyon steel slide-bolt bench legs enable you to position bench tops from 29" to 37" high.
- Built-in bolts secure legs within a 8" sliding range.
- Choose from 116 pre-engineered selections below.
- Add accessories at right to customize your choices.

COLOR INFORMATION, choose from the following

in stock **Dove Gray**
Add Prefix **DD** to Cat. No.
All steel components

in stock **Putty**
Add Prefix **PP** to Cat. No.
All steel components

Wedgewood Blue
Add Prefix **BB** to Cat. No.
All steel components

Ash
Add Prefix **AA** to Cat. No.
All steel components

*NOTE: Plastic Laminate Tops are only available in Dove Gray or Putty. Ash and Wedgewood Blue benches will come with Putty tops only.



Adjustable Slide-Bolt Leg Work Bench shown with shelf, stringer, "Perfect-Fit" Drawer, Pick Rack and Plastic Bins.

Note: Slide Bolt Legs and Benches are not compatible with Sky-Wal II™ components.

Workspace Furniture

Slide-Bolt Legs, One Pair

No. 2762 – 28" d x 29½" to 35½" h
No. 2763 – 34" d x 29½" to 35½" h

Back & End Stops, One Set

No. 2602 – for 60" x 28" bench
No. 2603 – for 60" x 34" bench
No. 2604 – for 72" x 28" bench
No. 2605 – for 72" x 34" bench

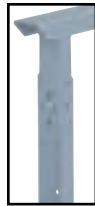

Pick Racks For Plastic Bins

No. 2630 – fits 60" w benches
No. 2631 – fits 72" w benches

Risers, One Set

No. 2625 – for 60" bench, 10½" d x 12" h
No. 2626 – for 72" bench, 14" d x 18" h
No. 2627 – for 48" bench, 14" d x 18" h
No. 2628 – for 60" bench, 14" d x 18" h
No. 2629 – for 72" bench, 14" d x 18" h

"Perfect-Fit" Drawer

No. 2794 – 15½" w x 20" d x 9" h

Blue Plastic Bins

No. 78203 – 4" w x 4" d x 2" h
No. 78206 – 4" w x 6½" d x 3" h
No. 78209 – 6" w x 9½" d x 5" h

Create your own design with components from above and tops listed on page 54 or, choose from pre-engineered selections below and add components to accessorize as needed.



Work Bench with Stringer

Work Bench with Stringer & "Perfect-Fit" Drawer

Work Bench with Stringer & Shelf

Work Bench with Stringer, "Perfect-Fit" Drawer & Shelf

60" w x 28" d				60" w x 34" d				72" w x 28" d				72" w x 34" d			
TOPS															
12-ga. Steel 1½" Thick															
2502AS	2503AS	2504AS	2505AS	2463AS	2464AS	2465AS	2466AS								
Pressed Wood Over Steel 1½" Thick															
2530AS	2531AS	2532AS	2533AS	2469AS	2470AS	2471AS	2472AS								
Laminated Hardwood 1½" Thick															
2540AS	2541AS	2542AS	2543AS	2506AS	2507AS	2508AS	2509AS								
Pressed Wood Over Wood 1½" Thick															
2444AS	2445AS	2446AS	2447AS	2514AS	2515AS	2516AS	2517AS								
Plastic Laminate – 180° Soft Front Edge 1½" Thick															
2476AS	2477AS	2478AS	2479AS	2518AS	2519AS	2520AS	2521AS								
Super Comp Top – 180° Soft Front Edge 1½" Thick															
2488AS	2489AS	2490AS	2491AS	2544AS	2545AS	2546AS	2547AS								
Laminated Hardwood – 180° Soft Front Edge 1½" Thick															
2565AS	2566AS	2567AS	2568AS	2577AS	2578AS	2579AS	2580AS								
Graphite Composite – Comfort Edge 1½" Thick															
2410AS	N/A	N/A	N/A	2411AS	N/A	N/A	N/A								

60" w x 28" d				60" w x 34" d				72" w x 28" d				72" w x 34" d			
TOPS															
12-ga. Steel 1½" Thick															
2522AS	2523AS	2524AS	2525AS	2401AS	2402AS	2403AS	2404AS								
Pressed Wood Over Steel 1½" Thick															
2534AS	2535AS	2536AS	2537AS	2405AS	2406AS	2407AS	2408AS								
Laminated Hardwood 1½" Thick															
2550AS	2551AS	2552AS	2553AS	2427AS	2428AS	2429AS	2430AS								
Pressed Wood Over Wood 1½" Thick															
2454AS	2455AS	2456AS	2457AS	2431AS	2432AS	2433AS	2434AS								
Plastic Laminate – 180° Soft Front Edge 1½" Thick															
2480AS	2481AS	2482AS	2483AS	2435AS	2436AS	2437AS	2438AS								
Super Comp Top – 180° Soft Front Edge 1½" Thick															
2492AS	2493AS	2494AS	2495AS	2439AS	2440AS	2441AS	2442AS								
Laminated Hardwood – 180° Soft Front Edge 1½" Thick															
2569AS	2570AS	2571AS	2572AS	2448AS	2449AS	2450AS	2451AS								
Graphite Composite – Comfort Edge 1½" Thick															
2420AS	N/A	N/A	N/A	2421AS	N/A	N/A	N/A								



Double Wide Work Benches



Flared Leg, 96" wide Work Bench shown with shelf, stringer, "Perfect-Fit" drawers and optional shelf risers.

- Now choose Flared Leg or Adjustable Leg work benches.
- Big, expansive 8' wide work surfaces – and no center-leg obstruction.
- Perfectly suited for two people, working side-by-side, or for accommodating large tools, parts and equipment.
- With 12-gauge steel tops (or laminated hardwood tops, featuring 180° soft front edges).
- All benches have capacity of 1000 lbs., shelves 150 lbs., based on evenly distributed loads.

COLOR INFORMATION, choose from the following

in stock	Dove Gray Add Prefix DD* to Cat. No.		Wedgewood Blue Add Prefix BB* to Cat. No.
	Putty Add Prefix PP* to Cat. No.		Ash Add Prefix AA* to Cat. No.



"Perfect-Fit"

Bench Drawers are 9" deep, hold items other drawers cannot handle.

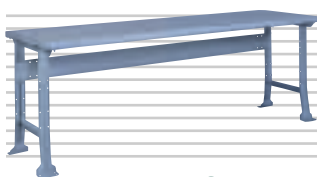

Bench with Stringer

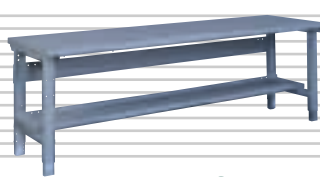

Bench with Stringer and Shelf

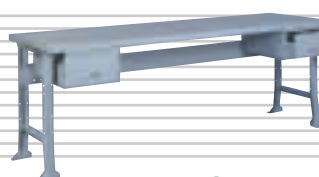

Bench with Stringer and Drawers

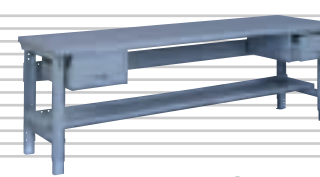

Bench with Stringer, Shelf and Drawers

Work Surfaces (Tops)	with Stringer Only	with Stringer & Shelf	with Stringer & Drawer	with Stringer Shelf & Drawer
96" wide	Flared Leg Benches – 34" high			
28"d Steel	2610	2612	2611	2613
34"d Steel	2614	2616	2615	2617
28"d Hardwood	2618	2620	2619	2621
34"d Hardwood	2622	2632	2623	2633
96" wide	Adjustable Leg Benches – 29" to 38" high			
28"d Steel	2610A	2612A	2611A	2613A
34"d Steel	2614A	2616A	2615A	2617A
28"d Hardwood	2618A	2620A	2619A	2621A
34"d Hardwood	2622A	2632A	2623A	2633A

Shelf Risers for 96" Wide Workbenches. Order 2 per bench.
No. 2624-48"w x 10½"d x 12"h **No. 2627**-48"w x 10½"d x 18"h

Description	Size	Cat. No.
Components		
Steel Bench Top	96"w x 28"d x 1¼"thick	2773
Steel Bench Top	96"w x 34"d x 1¼"thick	2774
Stringer	96"w	2653
Back and End Stops	96"w x 28"d	2606
Back and End Stops	96"w x 34"d	2607
Shelf	96"w	2646
Shelf and Stringer	96"w	2647
Laminated Hardwood Top	96"w x 28"d x 1¼"thick	2721
Laminated Hardwood Top	96"w x 34"d x 1¼"thick	2722
12" High Risers*	48"w x 10½"d x 12"h	2624
18" High Risers*	48"w x 10½"d x 18"h	2627
Leg Levelers		2757
Bench Legs (see facing page)		

Economical Work Benches

- Strong, heavy gauge steel legs combined with stringers, tops and accessories deliver sturdy, rigid work surfaces at low cost..
- Steel tops provide durability and abuse resistance.
- Tough resinwood tops are designed for general purpose use.
- Choose from five different pre-configured selections or build your own work station from Components.

COLOR INFORMATION.
Available only in Dove Gray

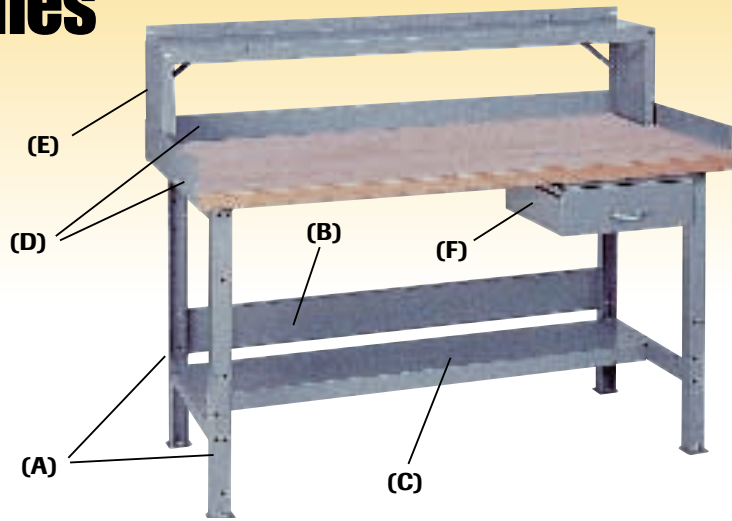
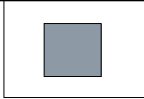

Cat. No.	BENCH DESCRIPTION	Cat. No.
Steel Top		Resinwood Top
VT600	With Stringer only	VT615
VT601	Stringer, Lower Shelf	VT616
VT602	Stringer, Shelf, Bench Drawer	VT617
VT603	Stringer, Shelf, Riser, Back & End Stops	VT618
VT604	Stringer, Shelf, Riser, Back & End Stops, Drawer	VT619

Cat. No.	Key	Description	Size
VT552	(A)	13-ga. Steel Legs	30"d x 32 1/4"h
VT560	(B)	Stringer	60"w
VT565	(C)	Lower Shelf	60"w x 12"d
VT570	(D)	Back & End Stops	60"w x 3"h
VT575	(E)	Riser Shelf	60"w x 10 5/8"d x 12"h
VT580	(F)	Bench Drawer	16"w x 16"d x 5"h
VT585		Kit to attach drawer to steel top only	
VT590		Steel Tops	60"w x 30"d x 1 3/4"h
VT595		Resinwood Tops	60"w x 30"d x 1 3/4"h

Wall Benches

Ideal for garages, tool maintenance cribs, wherever in-line work surfaces are favored. Install two or more units side-by-side to increase work areas, choose work surfaces to suit the tasks. Each 34" high unit includes top, channel steel bench legs and braces.



Component Legs For Wall Mounted Work Benches

Heavy-duty channel steel. Sold in pairs with braces. Dove Gray only.

No. DD2760 - 28"d x 32 1/4"h

No. DD2761 - 34"d x 32 1/4"h

60"w x 28"d	60"w x 34"d	TOPS		72"w x 28"d	72"w x 34"d
12-Gauge Steel					
		 1 3/4" Thick			
2502W	2503W			2504W	2505W
Pressed Wood Over Steel					
		 1 3/4" Thick			
2530W	2531W			2532W	2533W
Laminated Hardwood					
		 1 3/4" Thick			
2540W	2541W			2542W	2543W
Pressed Wood Over Wood					
		 1 3/4" Thick			
2444W	2445W			2446W	2447W
Plastic Laminate					
		 1 5/8" Thick			
2476W	2477W			2478W	2479W
Super Comp Top					
		 1 3/4" Thick			
2488W	2489W			2490W	2491W
Laminated Hardwood 180° Soft Front Edge					
		 1 3/4" Thick			
2565W	2566W			2567W	2568W
Graphite Composite					
		 1 1/2" Thick			
2420W	N/A			N/A	N/A

Bench Tops For Benches

Also See Accessories on facing page.

Choose The Bench Tops That Fit The Tasks!

COLOR INFORMATION, All tops are finished as shown below, except where noted at left.

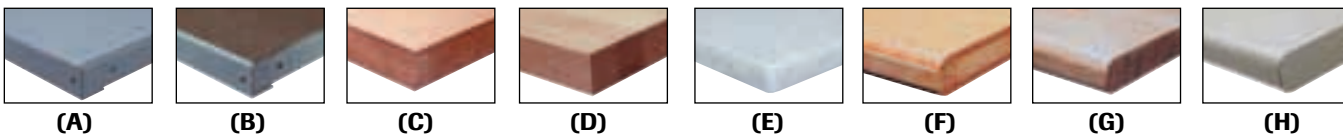

Square Edge Tops

(A) Solid 12-Gauge Steel – 1¾" thick

- Long service life. Ideal for heavy duty maintenance work.
- Easily cleaned and maintained.

(B) Tempered Pressed Wood Over Steel – 1¾" thick

- Combines strength of steel & resilience of wood.
- Won't mar smooth or finished parts. Ideal for heavy assembly work.

(C) Tempered Pressed Wood Over Wood – 1¾" thick

- Good all round top for general use. Thick, kiln-dried wood core surfaced with ¾" high-density tempered, pressed wood on both sides.
- Non-conductive, no warp and splinter free.
- Highly resistant to oil and chemicals.

(D) Laminated Hardwood – 1¾" thick

- Ideal for all precision work.
- 2" w x 1¾" Kiln-dried Maple or Birch strips waterproof glued for years of service.
- Natural finish, smooth work surface.

(E) Graphite Composite – 1½" thick

- Lightweight, high tech replacement for plastic laminate.
- Excellent for assembly, high tech production.
- Warp and splinter proof. Resists most chemicals, abrasion, corrosion, impact and moisture, including most oils and solvents.
- Gray marbled finish only. (Will not accept **No. 2783** bench drawer).

180° Soft Front Edges – For Comfort

(F) Super Comp Top – 1¾" thick

- Provides 40% harder work surface than laminated hardwood.
- Resistant to conventional liquids.
- Phenolic-board work surface is urea formaldehyde free.

(G) Laminated Hardwood – 1¾" thick

- Ideal for all precision work.
- 2" w x 1¾" Kiln dried Maple or Birch strips waterproof glued for years of service.
- Natural finish, smooth work surface.
- Used for electrical work, highly polished parts, fine tool and die making.

(H) Plastic Laminate – 1¾" thick

- 1¾" x 45 lb. density board core.
- Ideal for light duty assembly.
- Backer sheet on bottom and postforming plastic laminate on top and sides. Chip resistant.
- Available in Dove Gray or Putty.

ESD Static Dissipative (not pictured) – 1½" thick

- Same as Plastic Laminate (H), with surface resistivity of 10⁶ to 10⁹ OHMS, 100 volts.
- Includes ground cord. (See ESD work stations on pages 46-47).
- Available in Dove Gray or Putty.
- 180° soft edge

SIZE W x D	(A) Solid Steel	(B) Pressed Wood Over Steel	(C) Pressed Wood Over Wood	(D) Laminated Hardwood	ESD Static Dissipative	(E) Graphite Composite	(F) Super- Comp Top	(G) Laminated Hardwood	(H) Plastic Laminate
48" x 28"	2765	N/A	N/A	N/A	N/A	N/A	N/A	N/A	N/A
48" x 34"	2766	N/A	N/A	N/A	N/A	N/A	N/A	N/A	N/A
60" x 28"	2767	2737	2727	2717	2701	2711	2741	2751	2705
60" x 34"	2768	2738	2728	2718	2702	N/A	2742	2752	2706
72" x 28"	2769	2739	2729	2719	2703	N/A	2743	2753	2707
72" x 34"	2770	2740	2730	2720	2704	N/A	2744	2754	2708

Tough, Durable Steel Bench Legs

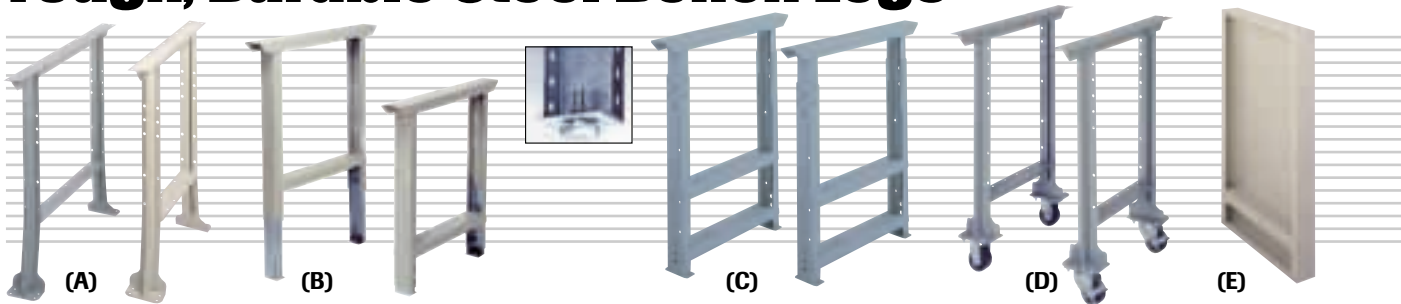

(A) Channel Legs

All welded. Flared footprints. Punched for floor anchoring, shelves and stringers.

- No. 2750** 32¼" h x 28" d
- No. 2755** 32¼" h x 34" d
- Not Flared**
- No. 2746** 28" h x 28" d
- No. 2748** 28" h x 34" d

(B) Adjustable Legs

27"–36¼" high. Welded cross members. Electrical knockouts on each leg. Punched for shelves, stringers.

- No. 2758** – 28" deep
- No. 2759** – 34" deep
- No. 2757** – Leg Levelers

(C) Slide-Bolt Legs

Adjust 29"–35½" high with built-in bolts. (not compatible with SkyWal components.)

- No. 2762** – 28" deep
- No. 2763** – 34" deep

Wood Screws

for replacing wood tops.
No. 2756 – ⅝" x 1"

(D) Roll-Around Legs

On 3" casters. Two swivel with brakes, two fixed 33¼" h.

- No. 2564-1** – 28" deep

Stringers – Add stability to legs (A) (B) (C).

- No. 2650** – Fits 48" w
- No. 2651** – Fits 60" w
- No. 2652** – Fits 72" w

(E) Panel Legs

Use with stringer/footrest for 60" or 72" w work stations.

- No. 2800** – 20" d x 32¼" h

Stringer/Foot-Rest

For use with two panel legs.

- No. 2803** – 54-69" w

COLOR INFORMATION, choose from the following

in stock Dove Gray Add Prefix DD to Cat. No.	in stock Putty Add Prefix PP to Cat. No.	WedgeWood Blue Add Prefix BB to Cat. No.	Ash Add Prefix AA to Cat. No.
---	---	--	---

Stringers are required on all benches utilizing legs (A) through (D).

**TOP THICKNESS
+ BENCH LEGS =
WORK SURFACE HEIGHT.**

Accessories For Work Benches

Accessories help keep tools, parts and equipment handy to speed your work.

Whether you choose pre-engineered selections (pages 22-23,40-54) or build your own work benches, Lyon accessories are easily added. Also, turn to pages 18-21 for new Sky-Wal II™ accessories.

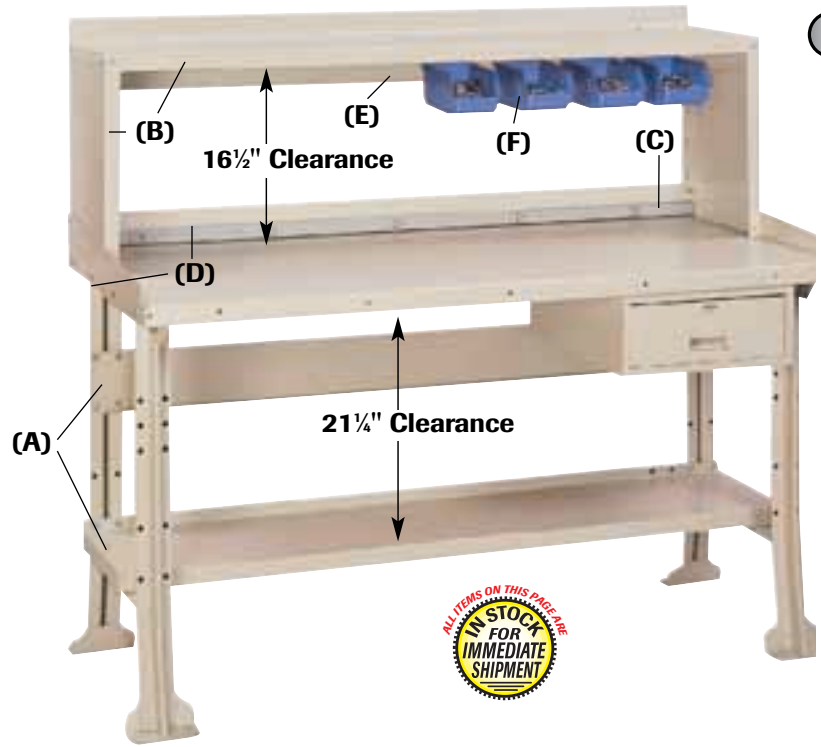

COLOR INFORMATION, choose from the following

in stock	Dove Gray Add Prefix DD to Cat. No. All steel components	Wedgewood Blue Add Prefix BB to Cat. No. All steel components
in stock	Putty Add Prefix PP to Cat. No. All steel components	Ash Add Prefix AA to Cat. No. All steel components

(A) Shelves/Stringers

- 13 1/4" deep shelf has 1" flange at rear for attaching to legs – providing additional reinforcement.
- May be attached to bench at any time. Stringer included.

- No. 2640** – for 48" w bench
- No. 2642** – for 60" w bench
- No. 2644** – for 72" w bench

Shelves Only

- No. 2643-1** – for 60" w bench
- No. 2645-1** – for 72" w bench

Stringer Only

- No. 2650** – for 48" w bench
- No. 2651** – for 60" w bench
- No. 2652** – for 72" w bench

(B) Shelf Risers

- Easy to reach shelf storage.
- Easily attached.

- 12" h x 10 1/2" d**
- No. 2624** – for 48" w benches
- No. 2625** – for 60" w bench
- No. 2626** – for 72" w bench

- 18" h x 14" d**
- No. 2627** – for 48" w benches
- No. 2628** – for 60" w bench
- No. 2629** – for 72" w bench

(C) Electrical Outlet Strip

- Attaches easily to almost anything.
 - Will carry 15 amps of current at up to 125v. UL approved. Install in accordance with local codes.
- No. 2661** – 48" w (5 outlets)
 - No. 2662** – 60" w (5 outlets)
 - No. 2663** – 72" w (8 outlets)

(D) Back and End Stops

- Extends 3" above top.
 - Ends taper to 1/2" at front.
- No. 2600** – for 48" x 28" bench
 - No. 2601** – for 48" x 34" bench
 - No. 2602** – for 60" x 28" bench
 - No. 2603** – for 60" x 34" bench
 - No. 2604** – for 72" x 28" bench
 - No. 2605** – for 72" x 34" bench

(E) Pick Racks for Plastic Bins

- Allows easy hanging of plastic bins for more on-hand storage.
- No. 2630** – for 60" w benches
 - No. 2631** – for 72" w benches

(F) Blue Plastic Bins

- No. 78203** – 4" w x 4" d x 2" h
- No. 78206** – 4" w x 6 1/2" d x 3" h
- No. 78209** – 6" w x 9 1/2" d x 5" h

Drawer Selections



Low Profile Drawers

- Overall case: 20" d x 6 3/4" h.
- Includes attachment angles and hardware.
- Will not fit on Graphite tops (No. 2711)

- No. 2788** – 15" w wide drawer
Actual: 14 1/2" w x 19 3/4" d x 5" h.
- No. 2789** – 21" w wide drawer
Actual: 20 1/2" w x 19 3/4" d x 5" h.

Low Profile Drawer Sets

- Includes four drawers, attachment angles and hardware.
- Will not fit on Graphite tops (No. 2711)

- No. 2788-4** – 15" w drawers
- No. 2789-4** – 21" w drawers

Double Height Drawers

- Overall case: 15 1/2" w x 20" d x 13 1/2" h.
- Actual drawer: 14 1/2" w x 19" d x 11 3/4" h.

- No. 2790** – Dbl. Height Drawer
- No. 2792** – Hanging folder adapter for Dbl. Height Drawers

"Perfect-Fit" Drawers

- 9" high to accommodate aerosol cans, containers, lunch boxes, purses, tools and all those other items that don't fit into other drawers.
- Overall case: 15 1/2" w x 20" d x 9" h.
- Actual drawer: 14 1/2" w x 19 3/4" d x 7 1/4" h.

- No. 2794** – single drawer
- No. 2794-3** – Set of three, with attach. angles and hardware.

Lock Kits

- No. 7037** – Fits No. 2788, 2789, 2790 & 2794 drawers.