



PRODUCT INFORMATION

Dero Swerve Racks

2946 Larimer St. Denver, CO 80205
303-295-1100 / 800-373-7693
FAX 303-295-2464
Email info@snyderequipment.com
www.snyderequipment.com

SWERVE RACK



“We have well over 1000 rail mounted Swerves on campus. The function and quality of the Swerve is great. Dero’s customer service is excellent and the flexibility of the rail mount is extremely convenient. All around it’s a first class product.”

- Steve Sanders, University of Minnesota

The Swerve Rack is our best selling product. The design of the Swerve mirrors the bike frame, thus providing superior bike support while making it easy to secure both the bike frame and wheel with a standard u-lock. Swerve Racks are popular with architects and universities because of their aesthetic design and space efficiency. Swerve Racks come in a variety of installation options: In ground mount, surface (foot) mount, and a freestanding rail mount. Each unit parks two bikes.

FEATURES

- Inexpensive bike parking
- Accommodates single and double sided parking
- Surface mounted or freestanding
- Easy installation



SWERVE RACK - Specifications and Space Use

Product Name:

Dero Swerve Rack
As manufactured by Dero Bike Racks

Bikes Parked per Rack: 2

Materials

1.9" OD schedule 40 pipe

Finishes

An after fabrication hot dipped galvanized finish is standard. 250 TGIC powder coat colors and a stainless steel option are also available.

Our powder coat finish assures a high level of adhesion and durability by following these steps:

1. Sandblast
2. Iron phosphate pretreatment
3. Epoxy primer electrostatically applied
4. Final thick TGIC polyester powder coat

Stainless Steel: 304 grade stainless steel material finished in either a high polished shine or a satin finish.

A rubbery PVC Dip is also available

Installation Methods

- In ground mount is embedded into concrete base. Specify In Ground Mount for this option.
- Foot Mount has two 2.5"x6"x.25" feet with two anchors per foot. Specify Foot Mount for this option.
- Rail Mounted Swerves are bolted to two parallel rails which can be left freestanding or anchored to the ground. Rails are heavy duty 3"x1.4"x3/16" thick galvanized mounting rails. Specify Rail Mount for this option.

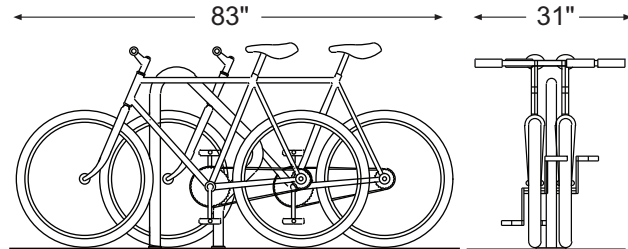
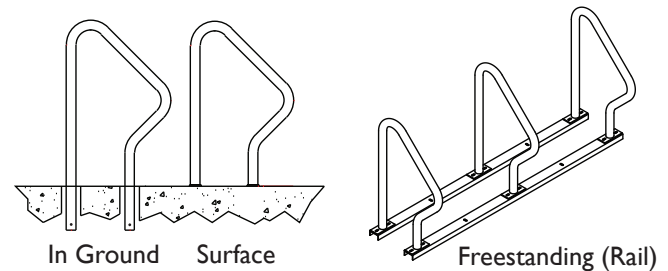
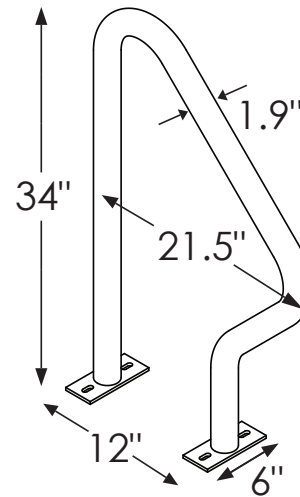

Setbacks

Wall Setbacks:

For Swerves set parallel to a wall:
Minimum: 24"
Recommended: 36"

For Swerves set perpendicular to a wall:
Minimum: 28"
Recommended: 36"

Distance Between Racks:

Minimum: 24"
Recommended: 36"

Street Setbacks:

Minimum: 24"
Recommended: 36"

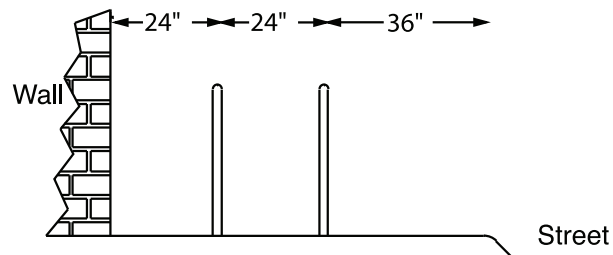
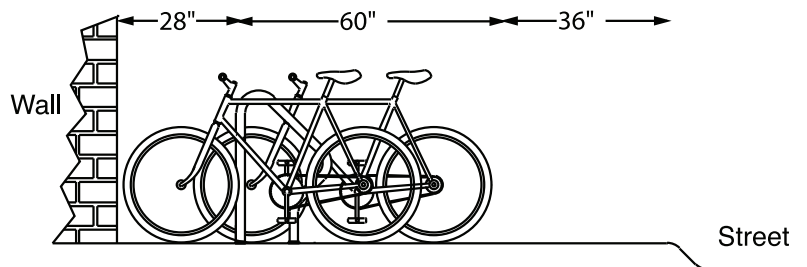

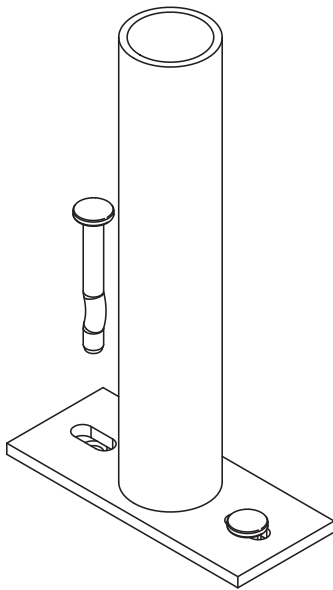

Concrete Spike

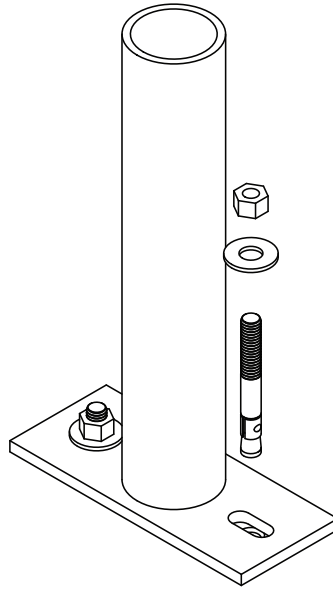

Wedge Anchor

The foot mounted Swerve Rack has 2.5"x6"x.25" mounting feet welded to each end. Each foot is anchored to the ground with two anchors.

Recommended Install Base Materials

Solid concrete is the best base material for installation. Ask your Dero Rack representative which anchor is appropriate for your application to ensure the proper anchors are shipped with your rack. Be sure nothing is underneath the base material that could be damaged by drilling.

Tools Needed for Installation

- Tape Measure
- Marker or Pencil
- Masonry Drill Bit
- Drill (Hammer drill recommended)
- Hammer
- Wrench/Ratchet

Installation

3/8" anchors are shipped with the rack. Place the rack in the desired location. Use a marker or pencil to outline the holes of the flange onto the base material. Drill the holes in accordance with the specifications shipped with the anchors. Make sure the holes are at least 6" away from any cracks in the base material.

Tamper Resistant Fasteners

The concrete spike is a permanent anchor. The top of the wedge anchor can also be pounded sideways after installation so that it cannot be removed. Other tamper resistant fasteners are also available for purchase.

When using the special tamper resistant nuts, always set and first tighten the anchors. Once the rack is installed, replace two nuts from the bracket (opposite sides from each other) with the tamper resistant fastener. **DO NOT OVERTIGHTEN** the tamper resistant nut.

If you have any questions about installation or other features of the Hoop Rack, please call DeroRacks at 888-DERO-RAX (888-337-6729).

SWERVE RACK - Installation Instructions - In Ground Mount

Installing into Existing Sidewalk

Core holes no less than 3" diameter (4" recommended) and no less than 6" deep into sidewalk. Fill holes with non-shrink epoxy grout. Place Swerve Rack into hole filled with epoxy. 33"-36" of the rack should remain above the surface. If the Swerve Rack is less than 33" high, it will not support the bike adequately. Make sure the rack is level and held in place until the grout has set.

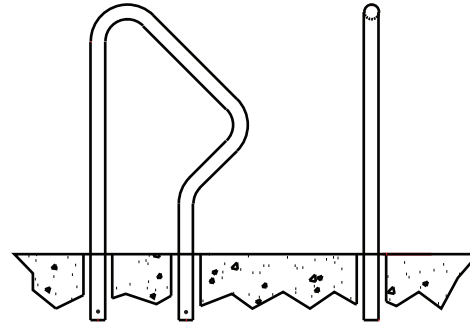

Installing Into a New Sidewalk:

Step 1

Use rack to measure exact location in pour bed.

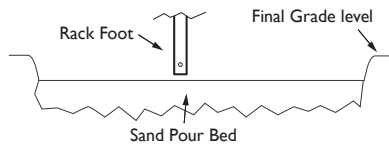

Step 2

Pound stakes into pour bed where ends of rack will sit. Slide rack ends into stakes. You may need to dig the ends of rack into the sand to make sure rack sits at least 33-36" above final grade level. The stakes keep the rack straight while the concrete is being poured.

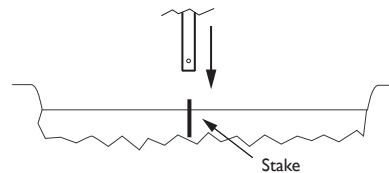

Step 3

Make sure rack is level and true, pour concrete around rack. Make sure rack is not touched until concrete has completely set.

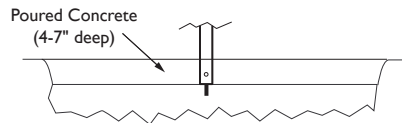

Sleeve Method:

Step 1

Place corrosion resistant sleeve (min. 3" inside diameter) in sand pour bed in exact location where the rack will be installed. Make sure top of sleeve is at same level as desired finished concrete surface. Fill sleeve with sand to keep it in place and prevent it from filling with concrete.

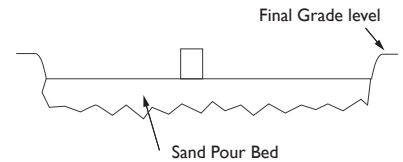

Step 2

Pour concrete and allow to cure

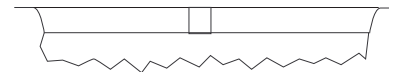

Step 3

After appropriate cure time, dig out sand from sleeves and pour in non-shrink epoxy grout. Insert racks and make sure they are level and at the appropriate height. Allow grout to set.

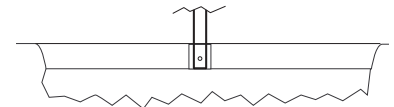

Note: Sleeve should have profile for maximum security.

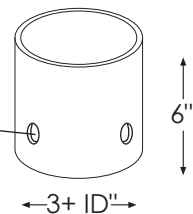

SWERVE RACK - Rail Mounted Swerves

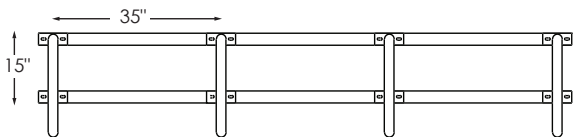
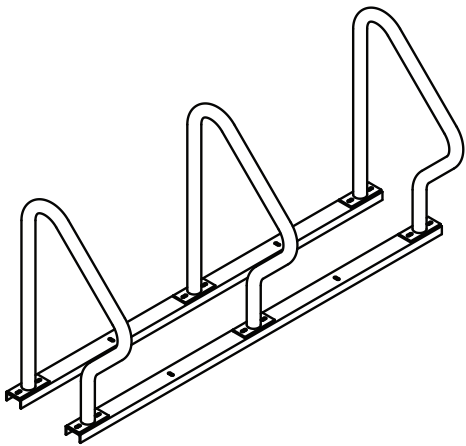

Rail Racks

Rail Mounted Swerves are standard foot mounted Swerve Racks attached with bolts to a rail in the configurations illustrated here. Rail Racks provide more flexibility than other mounting options while providing the same degree of security. Rail mounted Swerves can be left either freestanding or anchored to the ground using several anchors. This option allows for easier snow removal or sweeping. Installation of rail mounted Swerve Racks is also much less expensive than imbedded bike racks.*

Advantages to rail mounted Swerves:

- Easier and inexpensive installation
- Can be left freestanding or anchored to the ground
- Easier removal for sweeping and snow plowing

* Note: Though racks may be painted, the rails will remain with only a galvanized finish

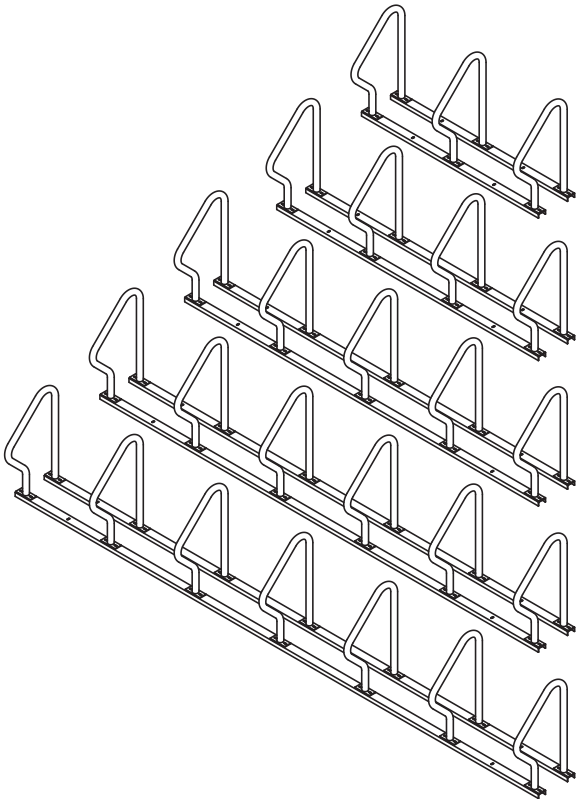

3 Swerve
Rail Rack
76" Long
Parks 6 Bikes

4 Swerve
Rail Rack
111" Long
Parks 8 Bikes

5 Swerve
Rail Rack
146" Long
Parks 10 Bikes

6 Swerve
Rail Rack
181" Long
Parks 12 Bikes

7 Swerve
Rail Rack
216" Long
Parks 14 Bikes

SWERVE RACK - Rail Mounted Swerves

Tools Needed for Installation:

- 9/16" Socket Set
- Two 4"x4"x25"(or larger) blocks
- 4 bolts, nuts and washers for every Swerve (included with rack). If using a tamper resistant nut, there are two tamper resistant nuts for each Swerve.

Install Steps

- ① Lay out the two channel beams where the rack will be placed. Place the two beams on top of the two blocks of wood so that the open part of the channel faces towards the ground
- ② Place Swerves on beams so holes in Swerve flanges line up with beam slots
- ③ Put bolts through Swerve flange holes and beams so bolt head faces up
- ④ HAND tighten the nuts
- ⑤ Once nuts are on, tip assembled rack over and use a 9/16" socket to tighten nuts. Before fully tightening nuts, make sure Swerves are straight on beams. If using tamper resistant nuts, use access tool to tighten nuts. Do not over-tighten the tamper resistant nuts.

Anchoring the rails

To anchor the rails to concrete, do not place bolts in the four corners of the rails/flanges. Place 5" wedge anchor through these holes into the concrete. Secure with nut.

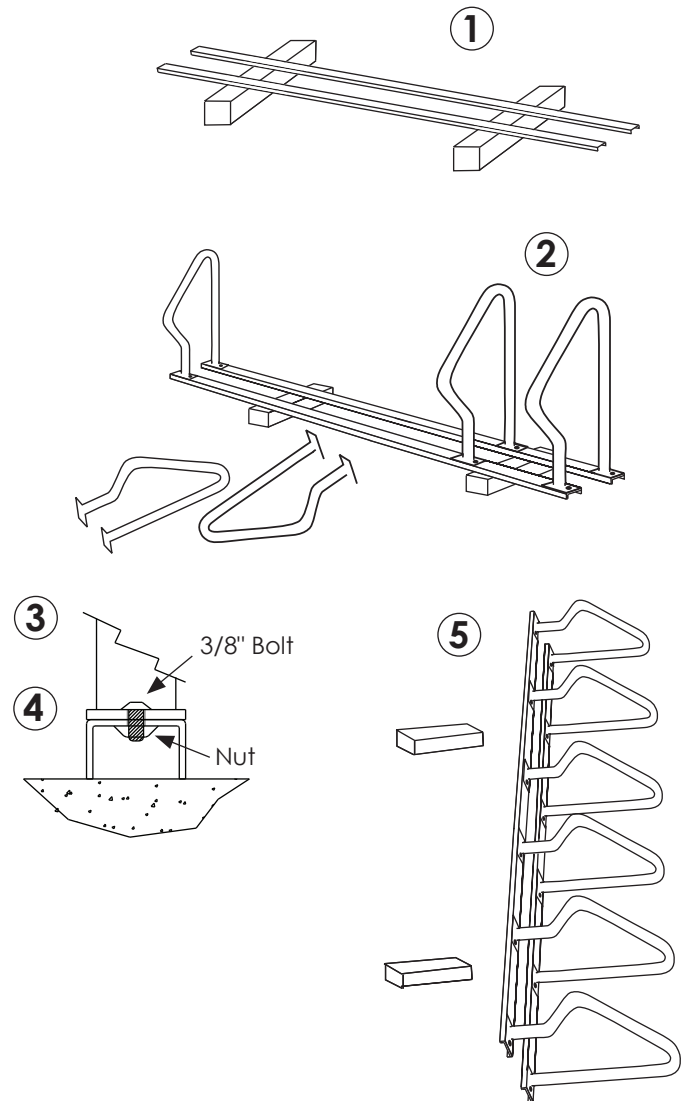
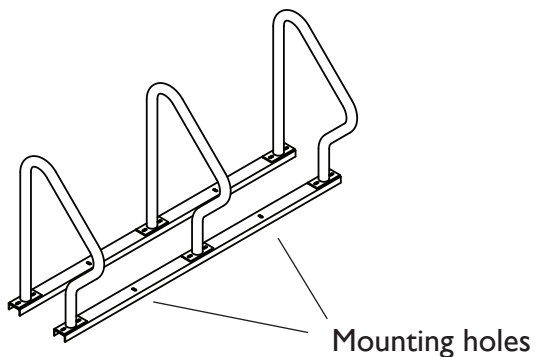

Rails anchored to surface

