

MobileTrak5 Installation Instructions

PLEASE OPEN ALL BOXES & CHECK TO MAKE SURE YOU HAVE ALL PIECES REQUIRED
READ ALL INSTRUCTIONS BEFORE STARTING



Tools Required for Assembly



7/16, 1/2 Wrench

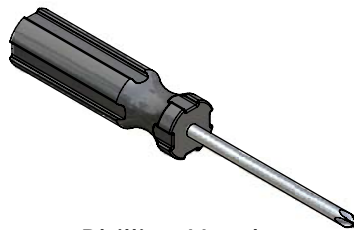

Phillips Head
Screwdriver

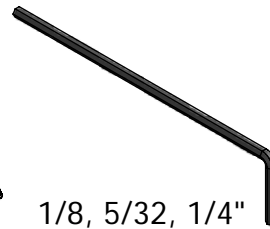

1/8, 5/32, 1/4"
Allen Wrenches

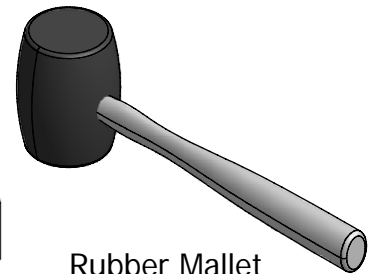

Rubber Mallet

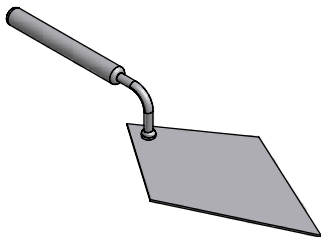

Mortar Trowel
(Optional)

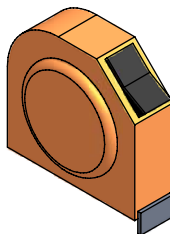

Tape Measure

Not Shown but required: Transit, Laser Level or Water Level; Electric Drill; 2' Bubble Level; 9" Bubble Level

Optional Equipment: Mortar Mixing Equipment

MobileTrak5 Rail Installation Instructions

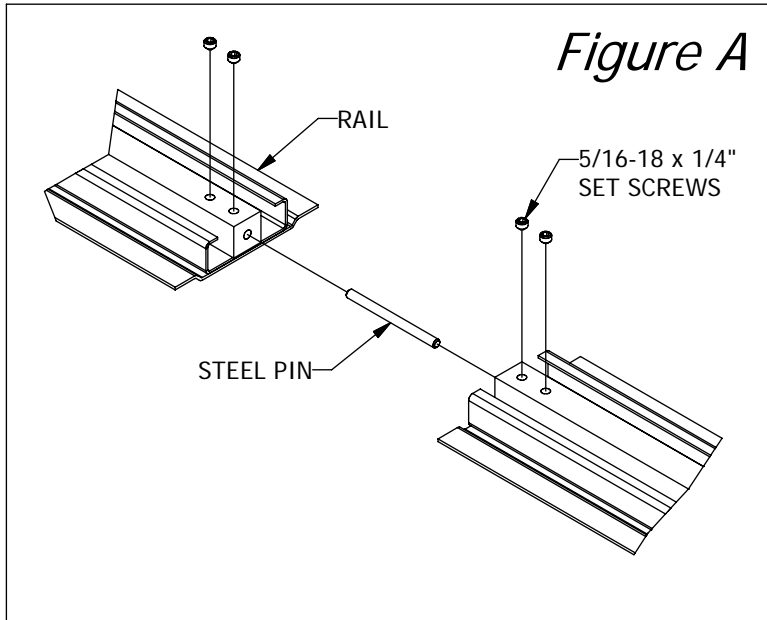

LAYING RAILS

1. The number of rails and their size depends on the size of the system. Refer to floor plan for system dimensions. The direction of each complete rail should be reversed on each run of rail. This can be done by positioning the first rails with all tags to the left, the second rail with all tags to the right, then alternate each additional rail. Rail sections are connected together with 1/4" steel pins and are secured with (4) 5/16-18 x 1/4" long set screws (see Figure A). Make sure rail sections are butted tightly together before tightening set screws.

2. Position all of the rail sections on the floor in the approximate location where they will be used. Use decking sections to correctly set the spacing between rails (see Figure B). Refer to decking layout sheet for rail sizes, decking placements and locations.

3. **IMPORTANT!** Verify the rail locations by measuring the centerline distance (see Figure C). The rail location can also be checked by placing a carriage on the rails and assuring that the wheels are centered on the rails and that the flanged wheels are approximately 1/16" to 1/8" from the rail sides.

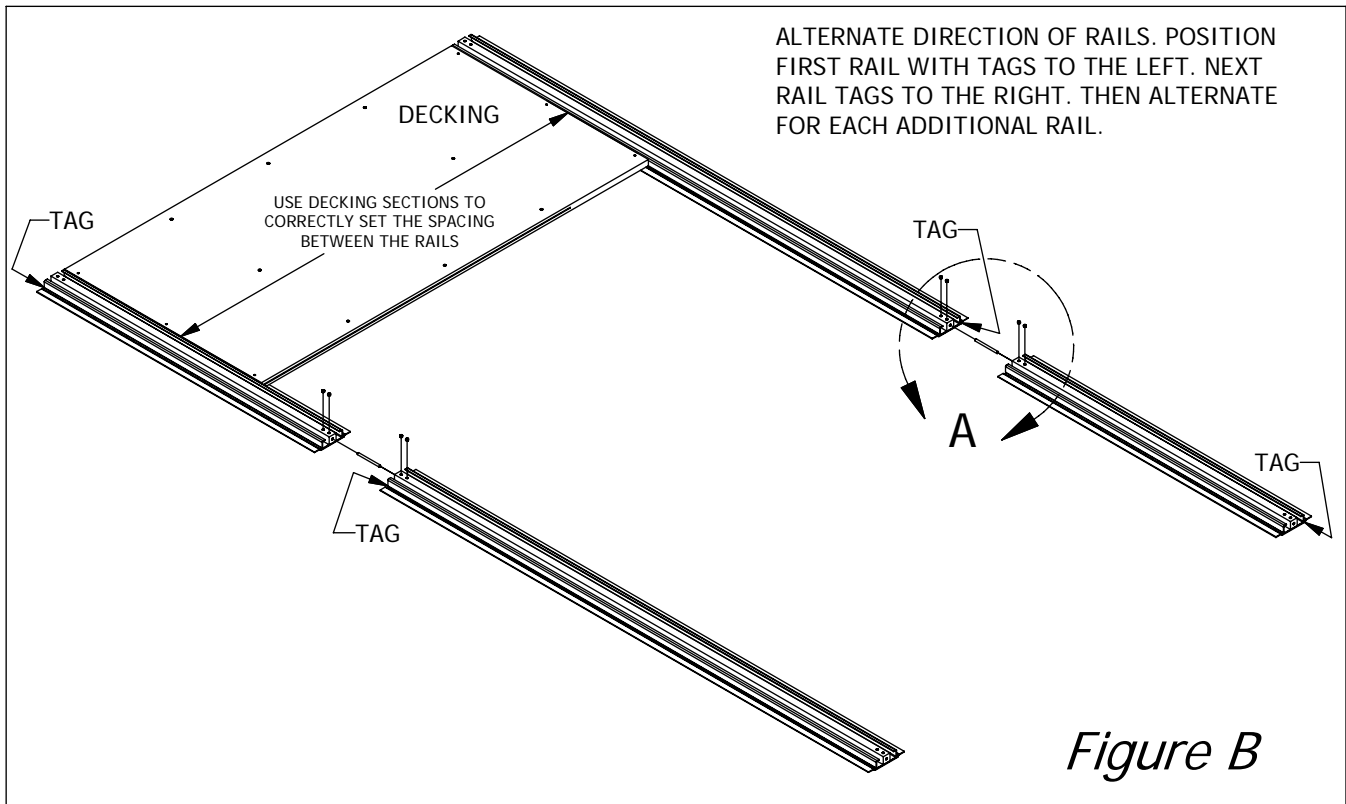

MobileTrak5 Rail Installation Instructions

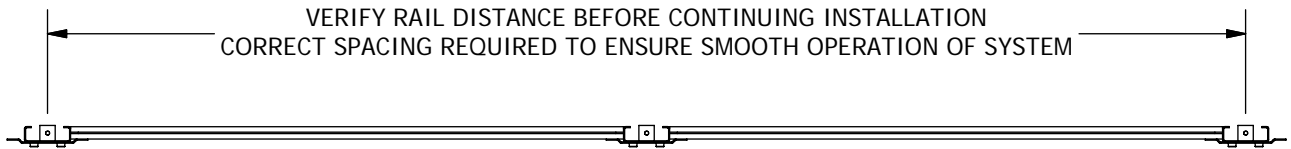

Figure C

FOR CARRIAGES SHORTER THAN 72", DIMENSION EQUALS CARRIAGE LENGTH MINUS 12"
FOR CARRIAGES LONGER THAN 72", DIMENSION EQUALS CARRIAGE LENGTH MINUS 24"

LEVELING RAILS

GROUTED: Using a water level, laser level, or transit (NOT BUBBLE LEVEL), locate the highest point on the rail/floor. Leveling screws (see Figure D) should be installed approximately 24" apart. Do not install screws in every threaded insert or you will not have enough screws for leveling the entire system (Optional: Shims can be used in place of leveling screws). Begin leveling the rails working out from the highest point. Use leveling screws or shims to position rails. There must be at least 1/2" between the floor and the bottom of the rail (see Figure E). Rails must be level from left to right, front to back, and from rail to rail. NOTE: Height of rails should not vary more than 1/16" across entire system. With rails leveled and in the correct position the rails should be screwed in place to the floor. Use fasteners that are correctly suited for the flooring. This will keep the rails in place while grouting. Mix grout (as per the instructions supplied with the grout) keeping in mind not to mix more than can be used in a short time period. Work with a small (4 to 6 foot) section of track at a time. Pack grout under the rail making sure not to leave any voids or air pockets (see Figure E). Pack grout until it starts to come out the other side of rail. Using trowel, remove grout from under rail flanges (see Figure E). Grout can be mixed with different amounts of water; more water makes it thinner and easier to pack but takes longer to set up; less water makes a thicker consistency that sets up faster, but is harder to prevent voids from forming under the rail. Mix to a consistency that you are comfortable with. Complete the installation of the grout and let it set up for at least 12 hours before going on to the next step.

ADJUSTABLE RAIL SYSTEM: Adjustable rails require the use of galvanized floor channels (see Figure D). Rails sit on floor channels, which provide sturdy surfaces for the leveling screws to sit on. Using a water level, laser level, or transit (**NOT BUBBLE LEVEL**), locate the highest point on the rail/floor. Install leveling screws into the threaded inserts located in the rails (threaded inserts are spaced 6" apart). Begin leveling the rails working out from the highest point. Rails must be level from the left to the right, front to back, and from rail to rail. NOTE: Height of rails should not vary more than 1/16" across entire system.

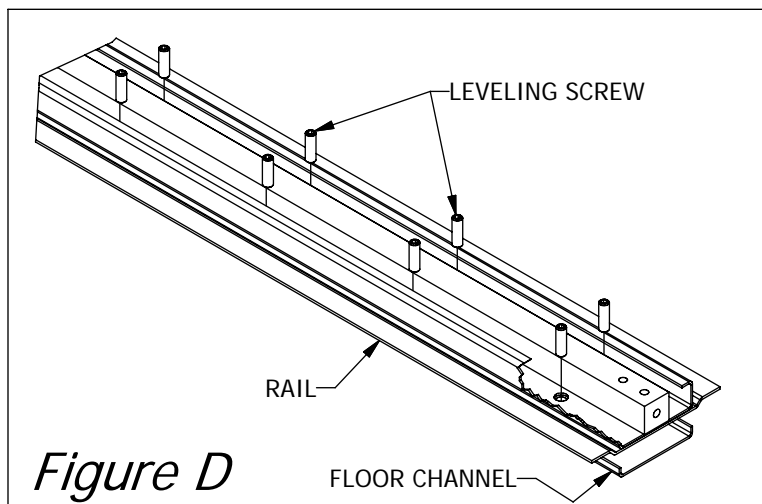

Figure D

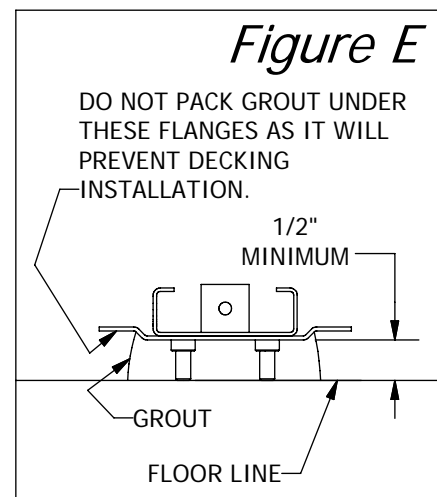

Figure E

MobileTrak5 Decking Installation Instructions

INSTALLING DECKING

Check to make sure that the decking has 1/4-20 T-nuts installed on the bottom. Use the decking layout sheet supplied with each job as a guide. Install the decking sections from left to right, making sure to install (3) splice plates between each section of decking (see Figure F). After all sections of decking are laid out, it must be secured to the rails. To secure: Drill pilot holes through the pre-drilled holes in the decking into the flange of the rail (space approximately 12" apart). Then use #10 x 1" long self tapping screws to secure decking to rails. Make sure that rails do not move while attaching decking (see Figure C. To make decking more rigid and eliminate "bounce", install 1/4-20 x 1 1/4" long leveling screws through the T-nuts in decking until they contact floor and level with a 2' bubble level (NOTE: try not to put weight on the decking while this is being done). Repeat for the remaining decking sections. (NOTE: If the system is equipped with side ramps, skip to the section on installing side ramps before attaching decking to system).

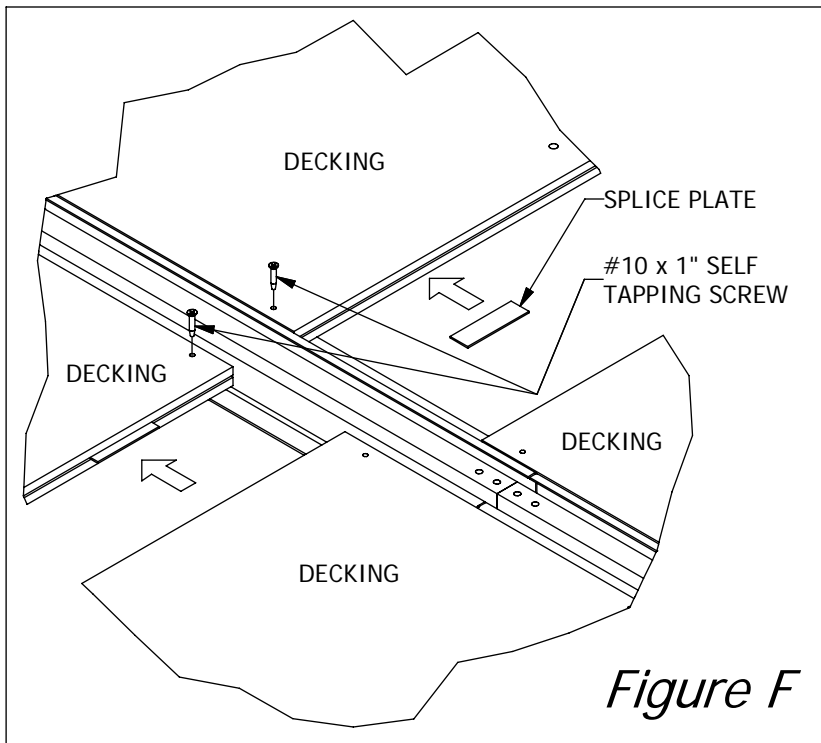

Figure F

INSTALLING DECK END TRIM (OPTIONAL)

Deck end trim is used in some cases to cover the exposed end of a system (see Figure G). Deck end trim is supplied in standard sizes. In most cases these pieces need to be cut in the field to fit. Deck end trim is to cover decking only. Do not cover the ends of the rails. After measuring and cutting pieces to length, attach to decking with the flange sitting on top of the decking with #10 x 3/4" pan head Phillips screws.

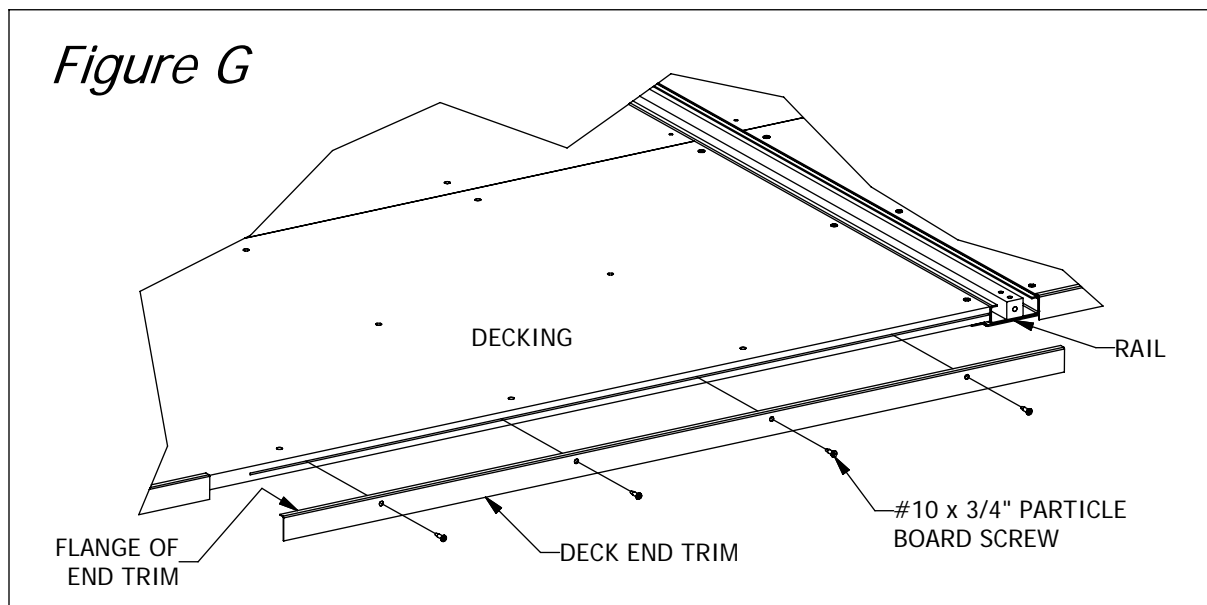
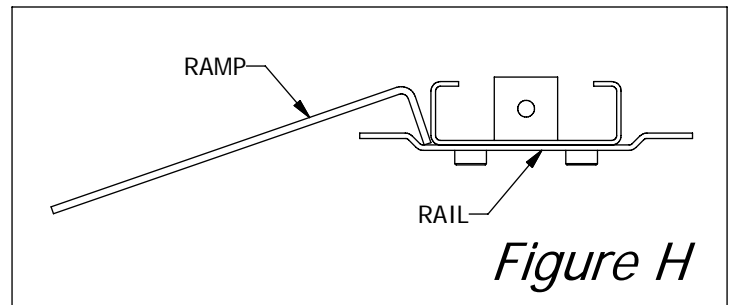

Figure G

MobileTrak5 Ramp Installation Instructions

INSTALLING RAMP

The ramp installs with the flange of the ramp resting on the lip of the front rails (see Figure H). The ramp does not need to be secured to rail but can be if necessary. To secure: Drill pilot holes (approximately 48" apart) through the ramp into the flange of the rail. Then using #10 x 1" long self-tapping screws, secure the ramp to rails. NOTE: Ramp runs entire length of system including under the stationary units.



INSTALLING SIDE RAMP (OPTIONAL)

In some cases, side ramps are installed on exposed ends of systems (see Figure I). Use #10 x 3/4" particle board screws to attach angle and shims to bottom side of decking board before installing decking board on system. The front ramp and the side ramp will need to be miter cut in the field. Refer to the customer layout for location of the ramps.

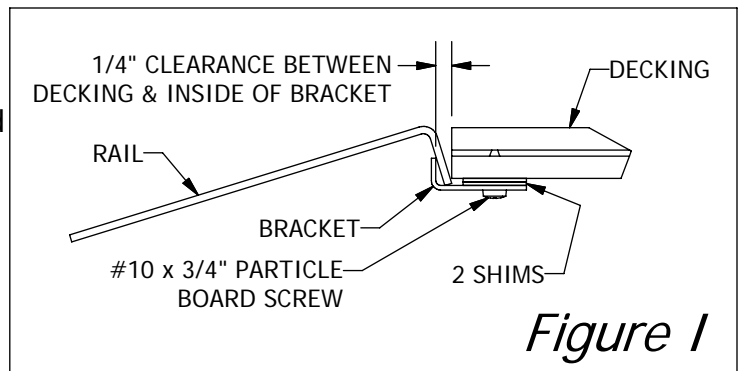

INSTALLING A.D.A. COMPLIANT RAMP (OPTIONAL)

Attach the metal ramp section to the wood ramp section using #10 x 3/4" particle board screws (see Figure J). Lay the assembled section of the ramp on to the front most rail and attach using #10 x 1 1/4" flat head Phillips Tek screws. Repeat step for additional sections of ramp. Be sure to use deck splice places between ramp sections.

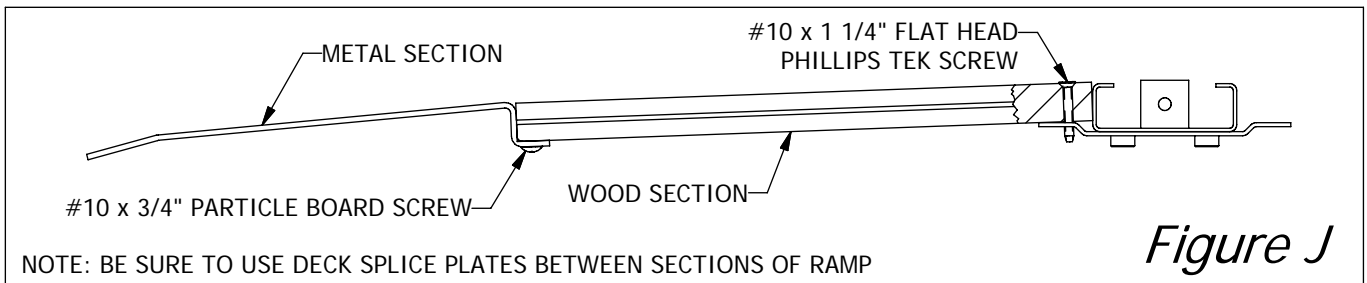

NOTE: BE SURE TO USE DECK SPLICE PLATES BETWEEN SECTIONS OF RAMP

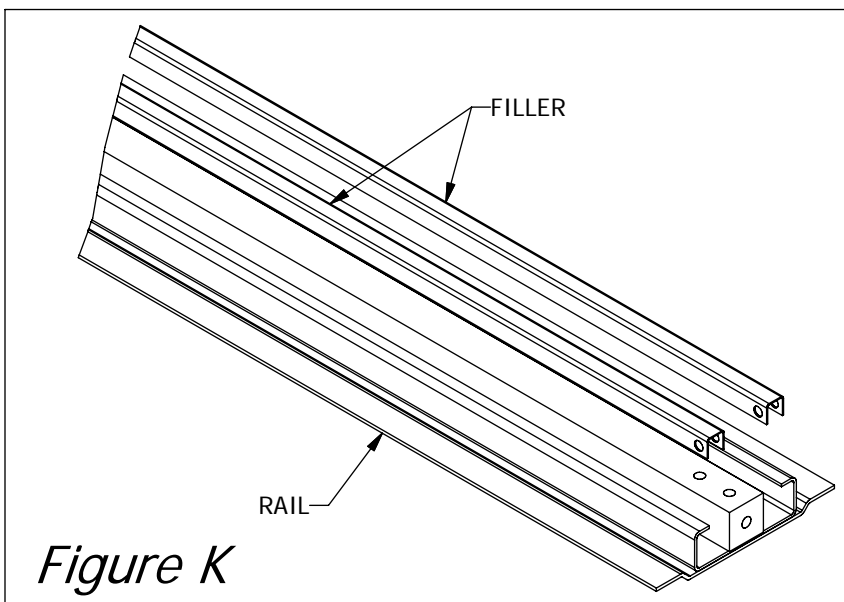

INSTALLING FILLER (OPTIONAL)

Track filler is used to fill the gaps between the anti-tip channel and the rail. It is placed in the rail over the adjuster screws (see Figure K). Two different sizes of track filler are used (see page 06).

MobileTrak5 Filler Installation Instructions

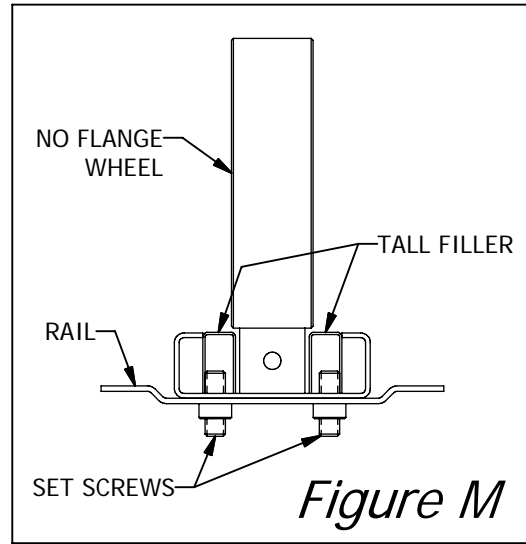
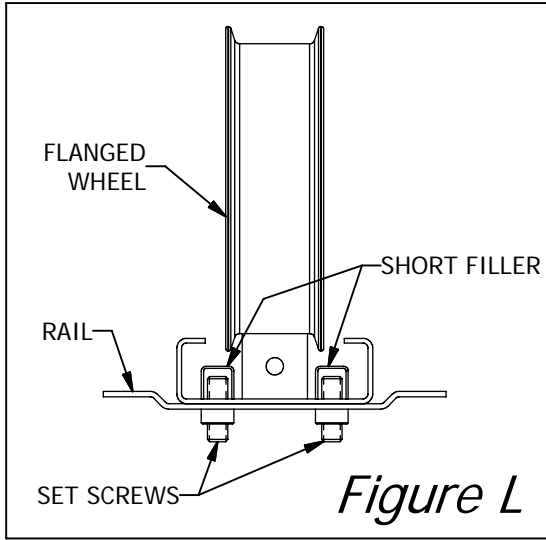

Tall track filler is used in all gaps except where the flanged part of a wheel is located (see Figure L). In cases where the flanged part of a wheel sits, a short track filler is used (see Figure M).

**THIS PAGE
INTENTIONALLY
LEFT BLANK**

MobileTrak5 Carriage Assembly Instructions

Carriages 108" long and shorter will be shipped in one piece. Carriages longer than 108" long will be shipped in sections. To reconnect sections, bolt a connector plate to the end of one carriage section (NOTE: The connector plate may be shipped already attached to one end of the carriage) using 5/16-18 x 3/4" hex head bolts and Nylock nuts. Do not tighten at this time. On manual and stationary, slide next section on to connector and bolt into position using 5/16-18 x 3/4 hex head bolts and Nylock nuts (see Figure N). Tighten all screws. On Mechanical Assist carriages, slide next section onto connector assembly. To connect drive shafts, place a woodruff key in the slot in the drive shaft and slide into coupler (see Figure N). Tighten coupler set screws to secure drive shaft. Bolt carriage sections together using 5/16-18 x 3/4" hex head bolts and Nylock nuts (see Figure O). Tighten all screws. Check drive shafts for binding. Repeat entire step for additional carriages.

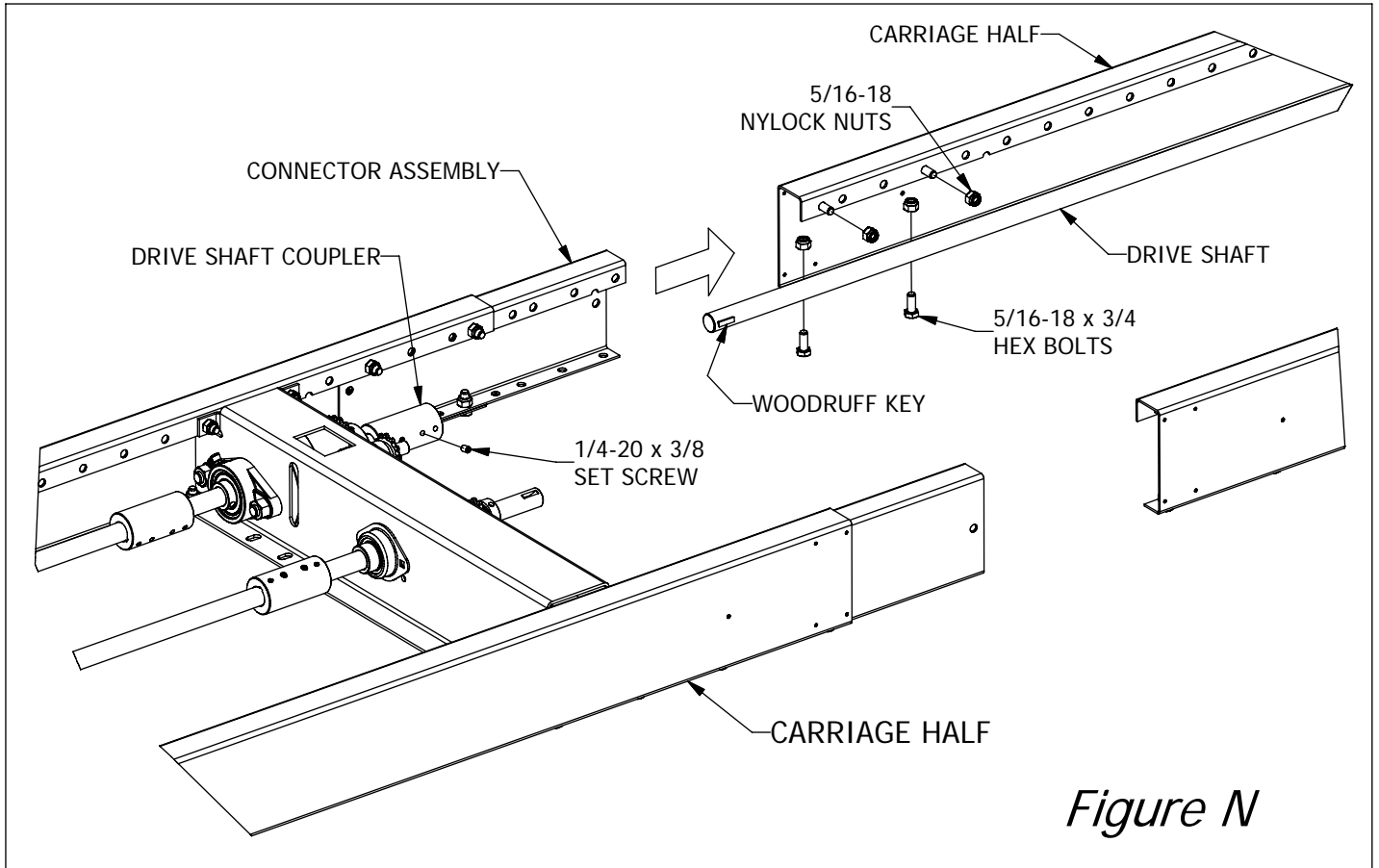

Figure N

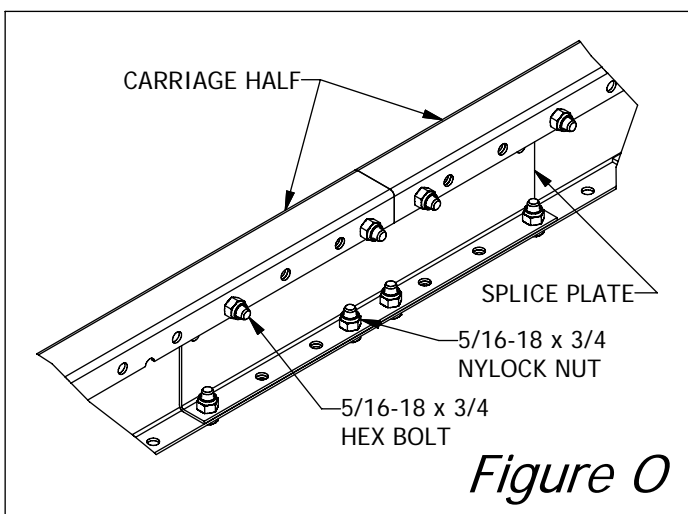
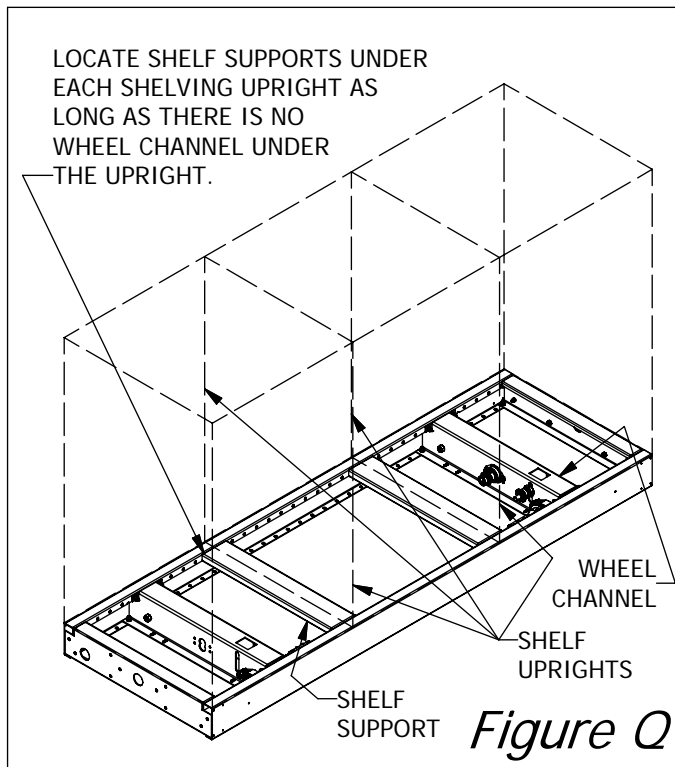
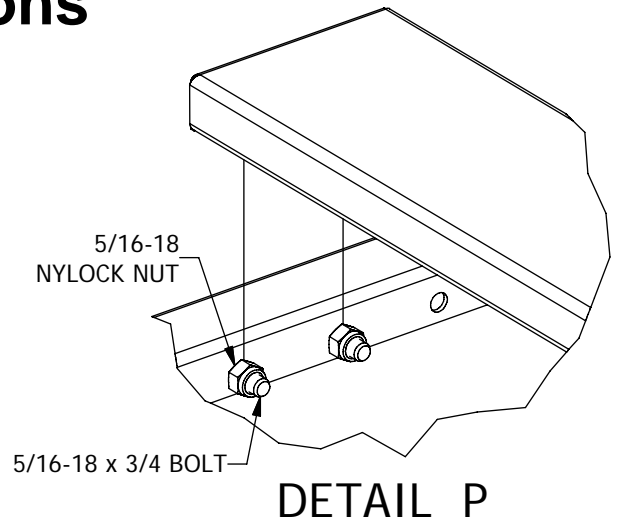
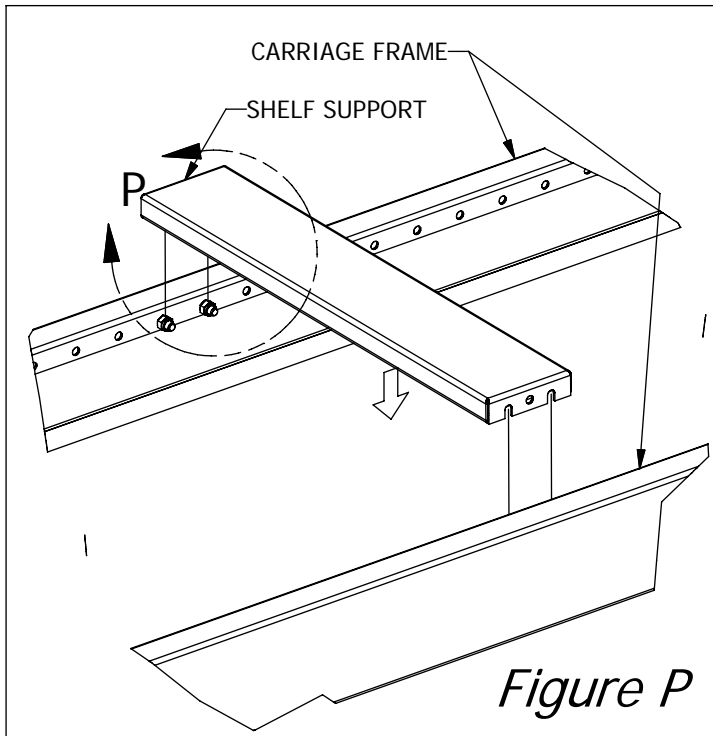

Figure O

MobileTrak5 Carriage Shelf Support Assembly Instructions



Measure location of shelving uprights on shelving that is being used (see Figure Q). Locate holes in carriage that will place the shelving supports under the uprights of the shelving being used. Insert 5/16-18 x 3/4 hex head bolts and 5/16 Nylock nuts in carriage and tighten most of the way (see Figure P). Slide shelf supports over bolts and finish tightening.

NOTE: Laying carriage on its side or upside down will make installation easier.

MobileTrak5 Anti-Tip Installation Instructions

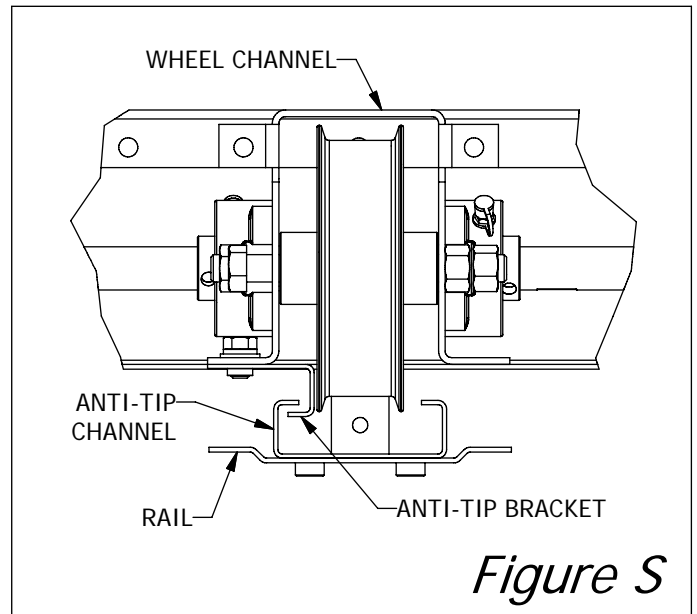
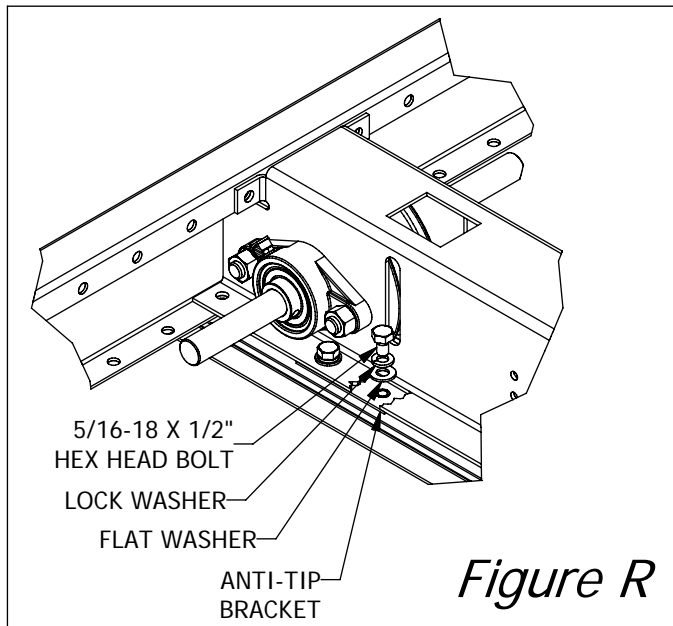

Four anti-tip brackets per carriage must be installed for anti-tip system to work properly. With carriages on track, slide one anti-tip bracket under carriage making sure that anti-tip bracket stays hooked under anti-tip channel. Attach bracket to wheel channel flange on underside of carriage using two 5/16-18 x 1/2" hex head bolts, lock washers and flat washers (see Figure R). Tighten screws making sure that bracket does not bind or scrape against anti-tip channel (see Figure S). Repeat for remaining anti-tip brackets. Anti-tip brackets are attached to outer most wheel channels.

MobileTrak5 Stationary Carriage Installation Instructions

Use a movable carriage to align stationary carriage before screwing carriage to decking. Stationary platforms can be mounted two ways (which way depends on the type of installation being done).

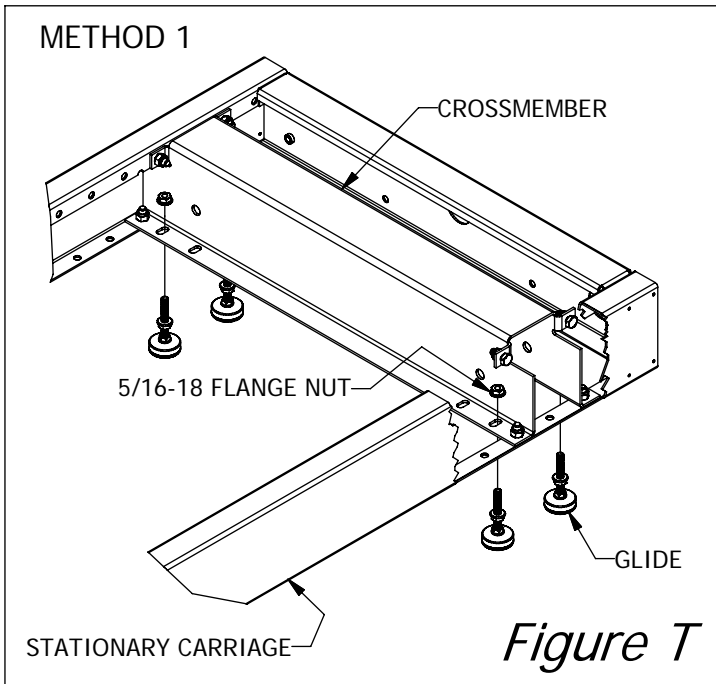

Method 1 (Figure T): Stationary carriage sits on floor. Glides must be mounted to each crossmember on the underside of the stationary carriage (four glides per crossmember).

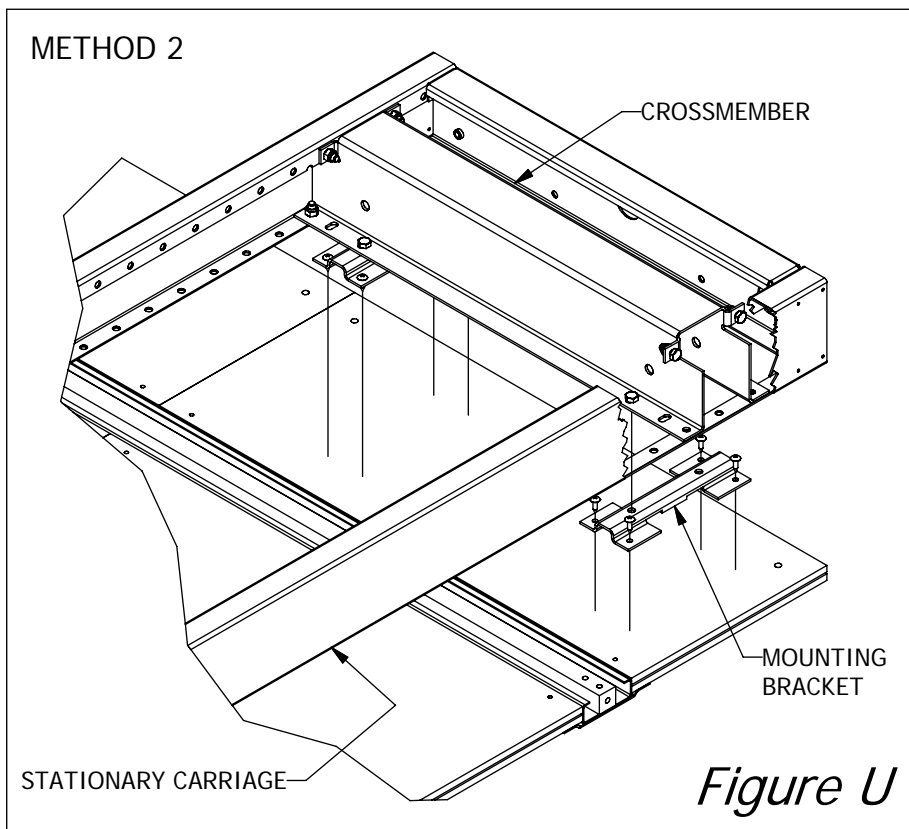

Method 2 (Figure U): Stationary carriage is mounted directly to top of decking. Attach two stationary mounting brackets to each crossmember on the stationary carriage with two 5/16-18 x 1/2" hex head bolts per mounting bracket. After installing mounting brackets attach stationary carriage(s) to decking using #10 x 3/4" Phillips pan head wood screws (4 screws per bracket).

Optional: Systems may have shelving sitting directly on floor adjacent to the movable carriages and act as end stops for the system. If this method is used, shelving must be anchored to floor (anchoring fasteners must be supplied by the installer).

MobileTrak5 End Stop Installation Instructions

End stops must be installed if:

1. System has no stationary carriages.
2. System has only one stationary carriage.
3. System has stationary carriages, but they are not secured to floor or top of decking.

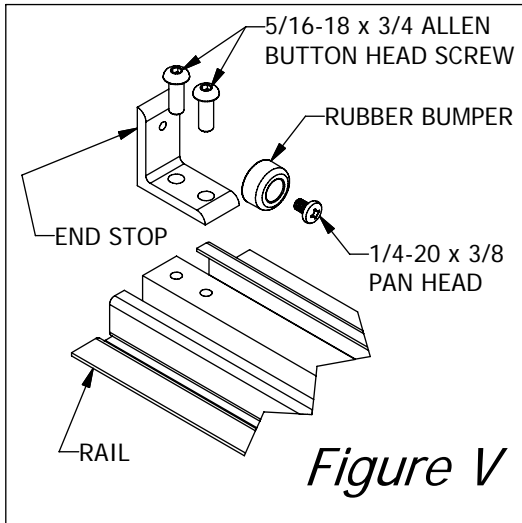

ANGLE END STOP BRACKET

Using two 5/16-18 x 3/4 allen button head screws, fasten end stop on top of rail (see Figure V). Attach rubber bumper to bracket with 1/4-20 x 3/8" pan head Phillips screw.

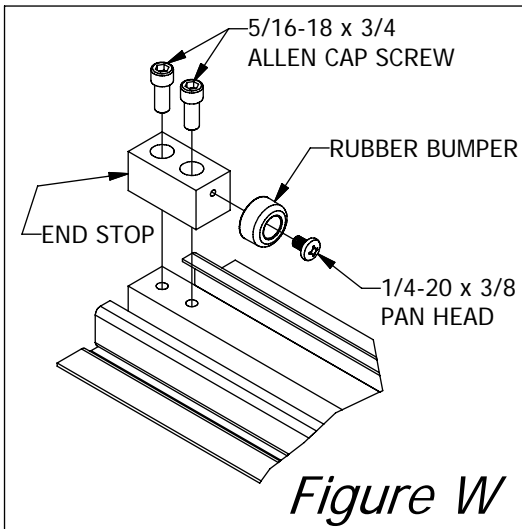

ALUMINUM END STOP BRACKET

Using two 5/16-18 allen cap screws, attach end stop bracket on top of rail with rubber bumper facing mobile carriages.

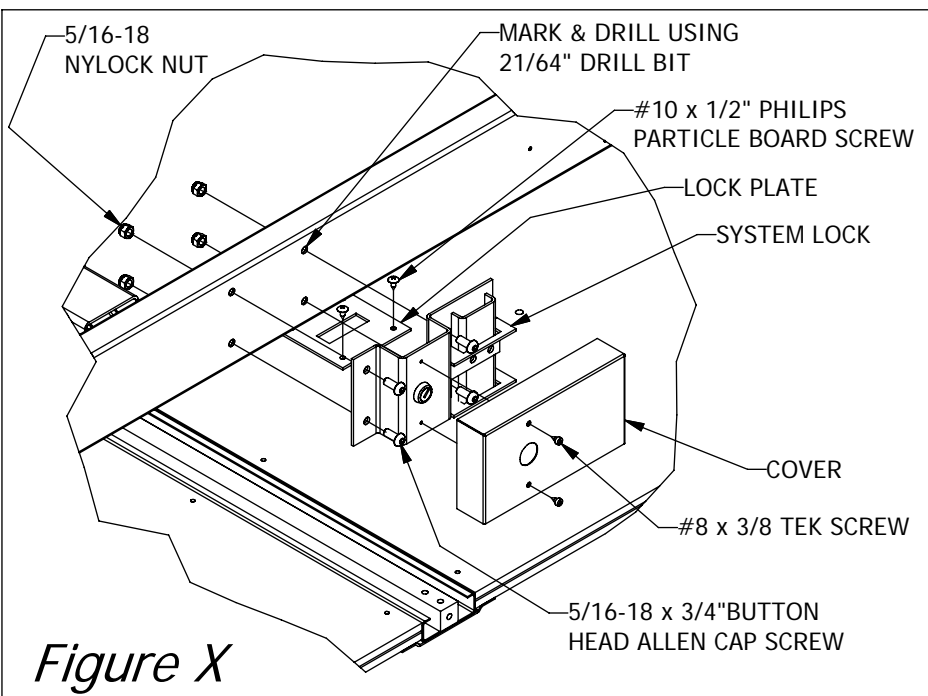

INSTALLING CARRIAGE SYSTEM LOCK (OPTIONAL)

Remove cover from system lock. Place system lock in desired location on side of carriage. Using the system lock as a template, mark the mounting holes and drill using a 21/64" bit. Attach the lock using the 5/16-18 x 3/4" button head allen cap screw.

MobileTrak5 Carriage Cover Plate Installation Instructions

BEFORE CONTINUING, MAKE SURE THAT THE CHAIN TENSION AND TENSIONER ARE TIGHT!

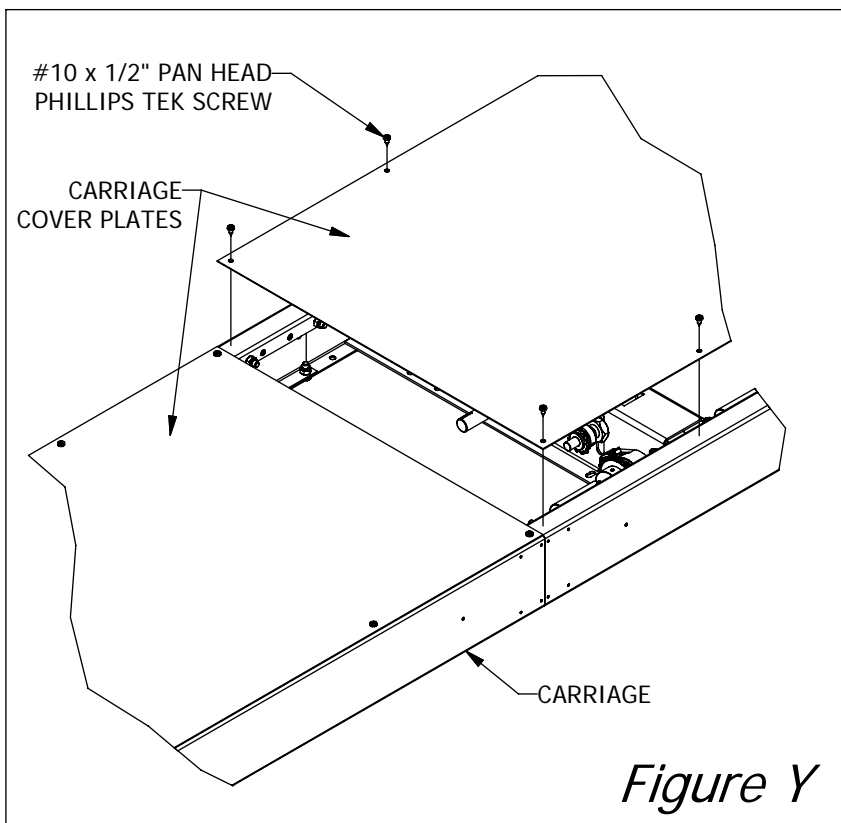
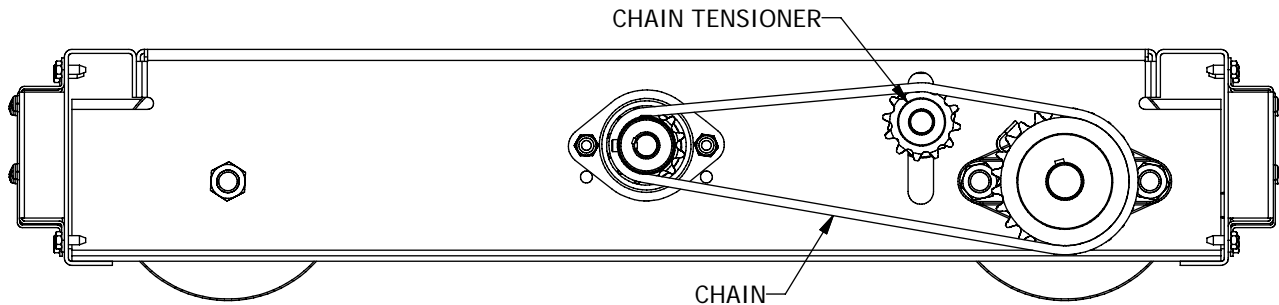

INSTALLING CARRIAGE COVER PLATES (OPTIONAL)

Typically a carriage cover plate is used where the shelving is not as large as the carriage it's attached to. Center the carriage cover plate on the appropriate carriage and secure using #10 x 1/2" long pan head Phillips Tek screws.

MobileTrak5 Shelving Installation Instructions

Assemble shelving on carriage following shelving manufacturers assembly instructions. NOTE: Shelving must be secured to the carriage to eliminate the possibility of shelving falling over or off the carriage. USE CAUTION when drilling or screwing into carriage. Drilling or screwing into carriage wheels will cause carriages to be difficult, if not impossible to move.

When racks or shelving units are mounted back to back on carriages, it is required that they be bolted together back to back and side to side using hardware supplied by installer.

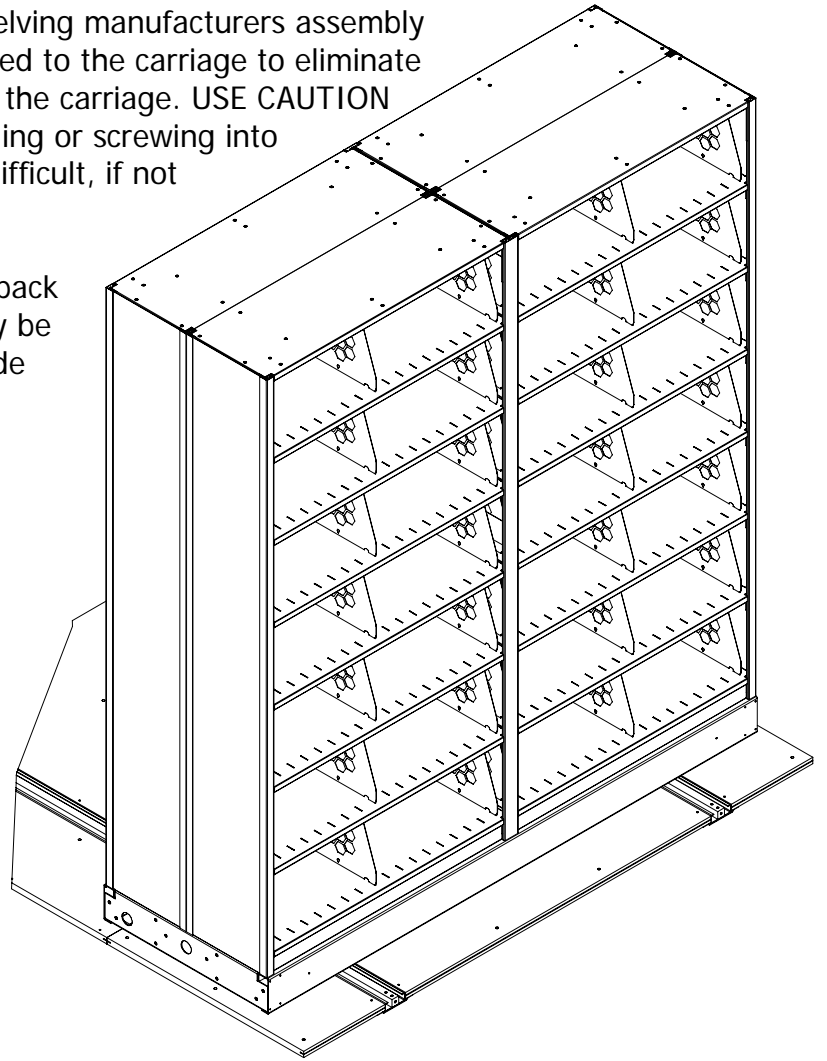

MobileTrak5 Drive Tower Installation Instructions

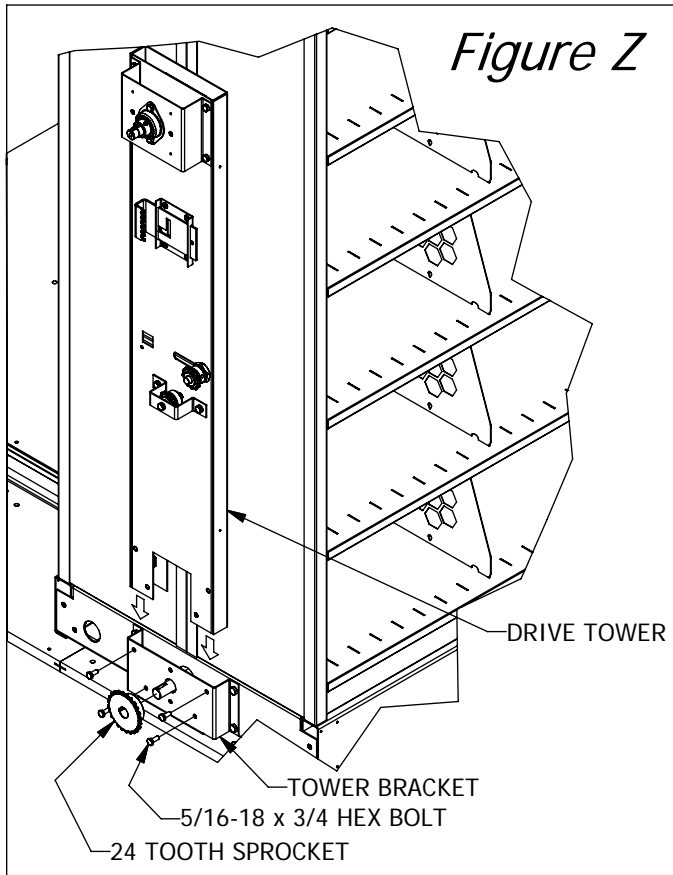

Install the drive tower into top of tower bracket on carriage (see Figure Z). Fasten tower to tower bracket using 5/16-18 x 3/4" hex head bolts.

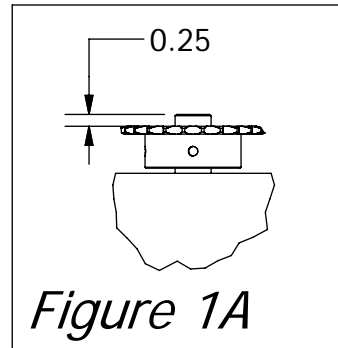

Place woodruff key in drive shaft. Slide sprocket over drive shaft, aligning woodruff key with sprocket. Slide sprocket so that front is 1/4" from the front of the driveshaft (see Figure 1A). Place blue locktite on 1/4-20 set screw and tighten.

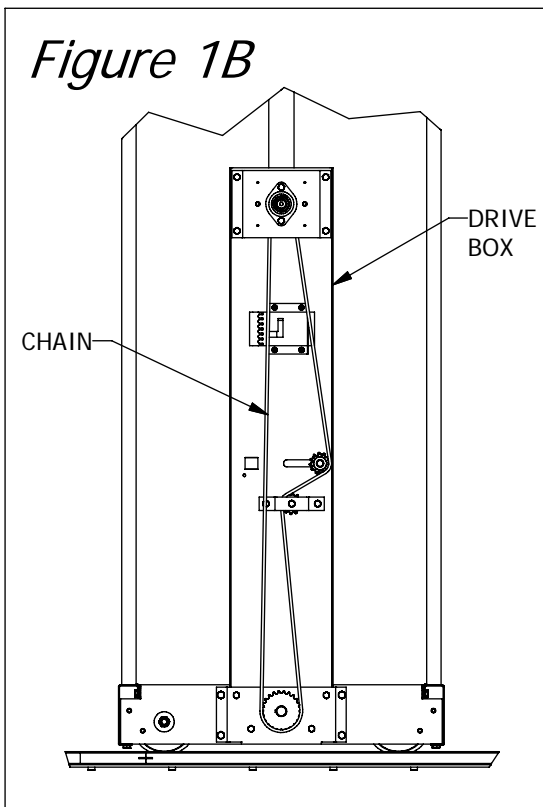

Route chain on drive tower as shown in Figure 1B. Connect ends of chain together using master link. Adjust chain tensioner so that chain is tight. Do not put too much tension on the chain or it will cause poor operation. Test chain tension by turning handle shaft.

MobileTrak5 Drive Tower Cover Installation Instructions

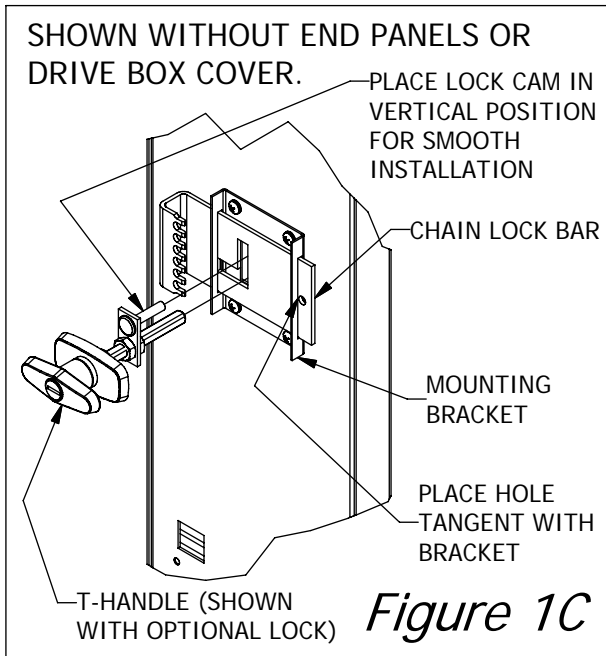

Before installing drive tower cover or mechanical end panel, the chain lock bar and T-handle need to be aligned. Slide the lock bar so that the hole in the chain lock bar is tangent with the right side of the mounting bracket (see Figure 1C). Turn T-handle so that the lock cam is in the vertical position, which will allow it to slide in the lock bar.

If system includes fully enclosed end panels, skip to page 19.

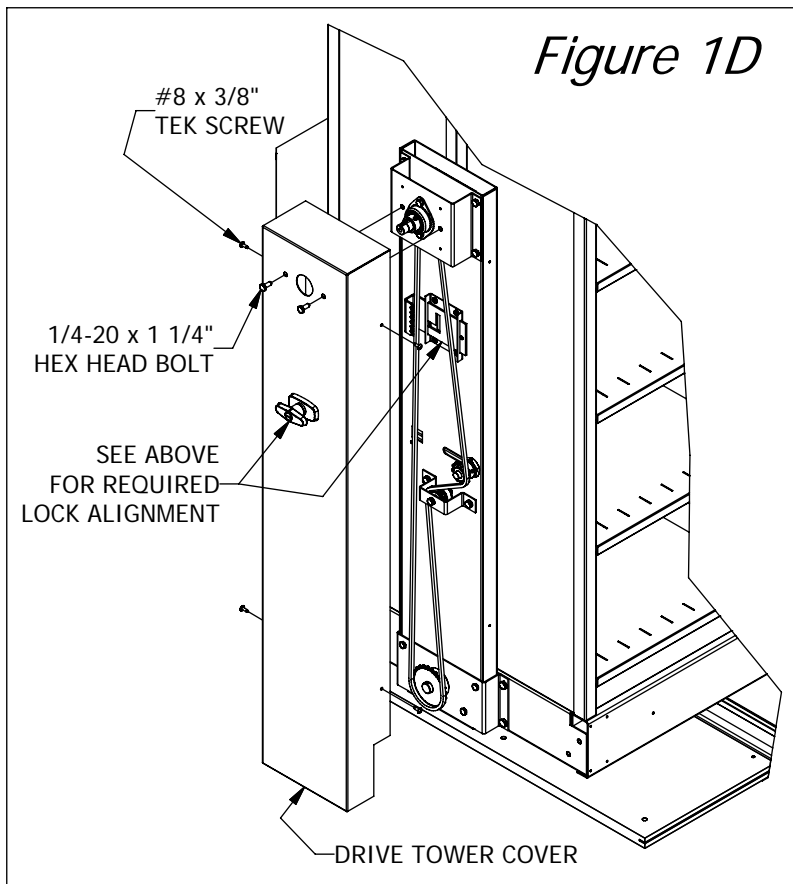

If using drive tower cover, place cover over drive tower. Secure in place using (4) #8 x 3/8" Tek screws (see Figure 1D). Check to make sure that the T-handle engages lock bar by turning handle to locked position and ensuring the carriage is locked in position. Continue to page 23 for handle installation.

MobileTrak5 Upright Installation Instructions

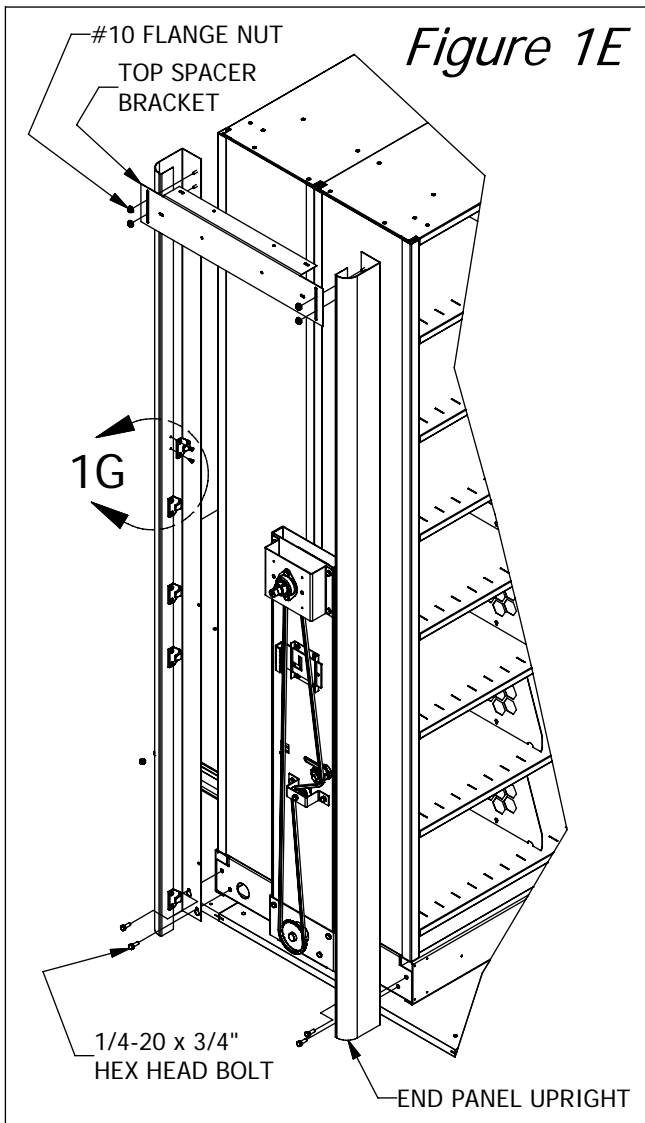

Mount end panel uprights using (4) 1/4-20 x 3/4" hex bolts (see figure 1E). Do not fully tighten at this time. Place top spacer bracket over studs on top of uprights. Finger tighten (4) #10 - 24 flange nuts on studs. Making sure that uprights are square, and top spacer's flange is against top of shelving; tighten 1/4-20 bolts and #10-24 flange nuts.

Screw #8 x 1/2" Tek screws into top of shelving on carriage through holes in top spacer bracket (see Figure 1F).

Attach female end panel clips to uprights using (2) #8 x 1/2 sheet metal screws per clip (see Detail 1G). The clip opening should be facing away from shelving. If using 3 piece end panels, clips will be used on all sets of holes in uprights. If using a 1 piece end panel, clips will be used in bottom holes, top holes, and the fourth set of holes from the bottom.

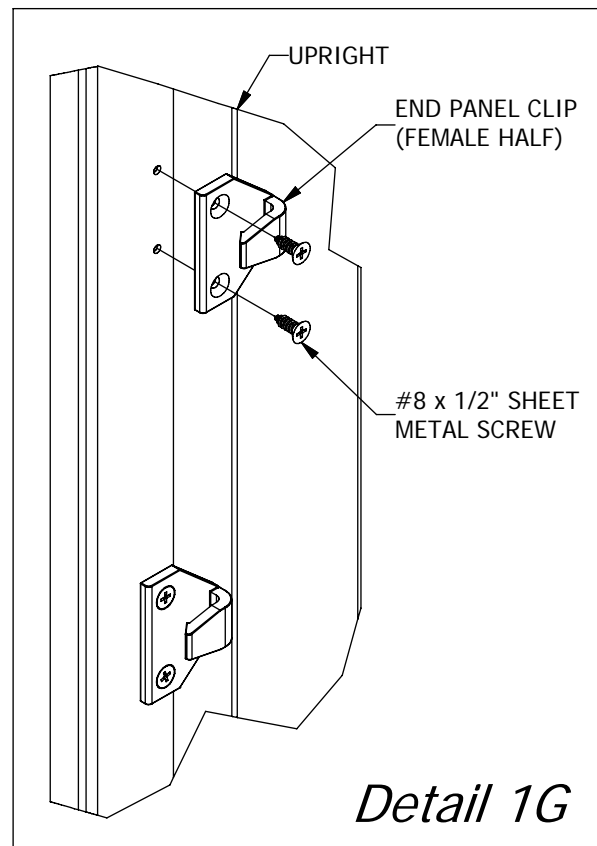
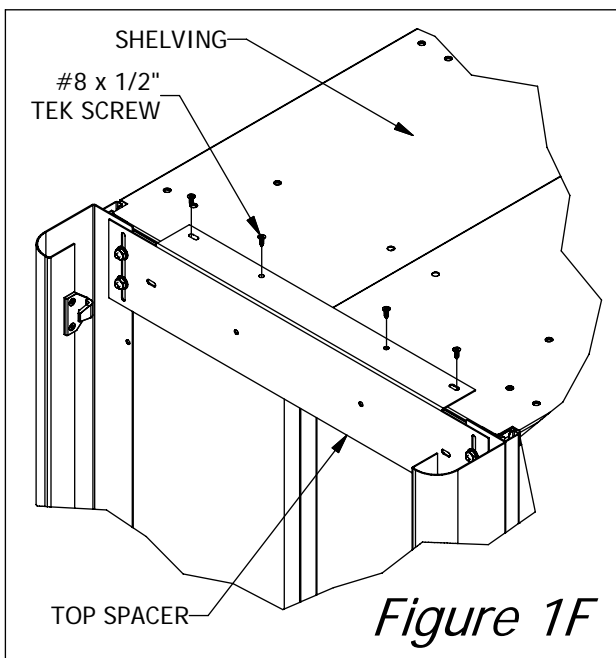

**THIS PAGE
INTENTIONALLY
LEFT BLANK**

MobileTrak5 End Panel Installation Instructions

Install male end panel clips to end panels using (2) #8 x 1/2 sheet metal screws per clip. Place flat side of male clip towards outside of end panel (see Figure 1J) Install 6 clips per one piece panel (see Figure 1H). Install 4 clips per panel on 3 piece end panels, making 12 clips in total (see Figure 1I).

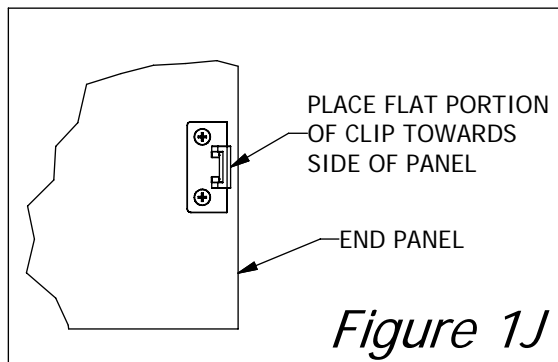
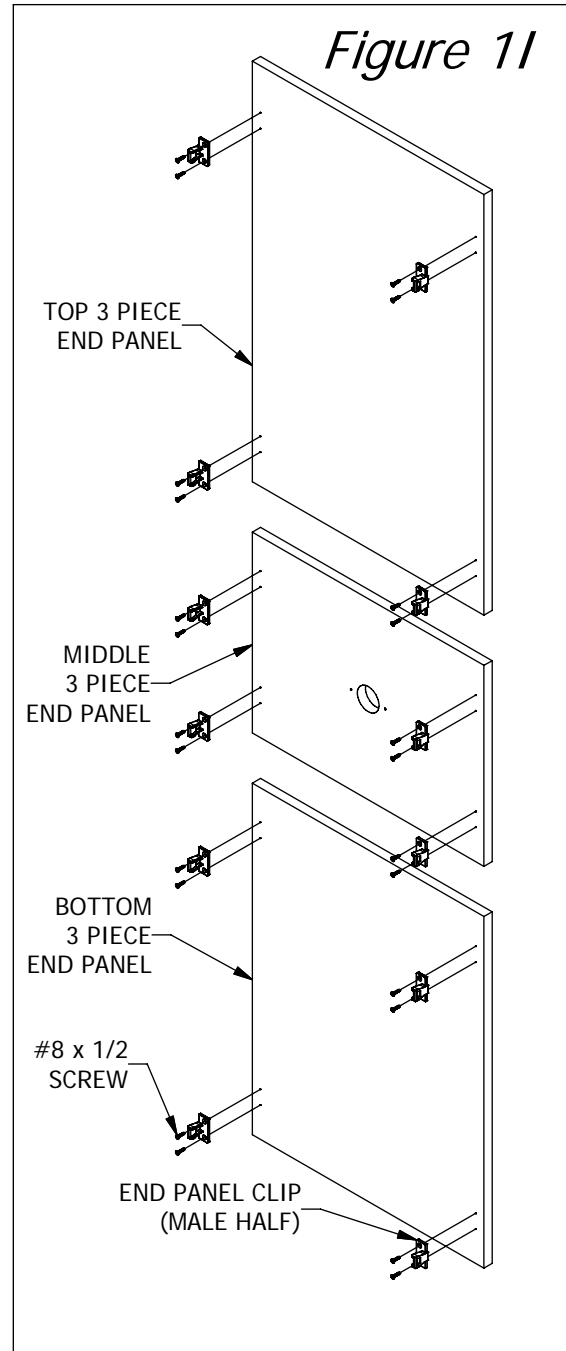
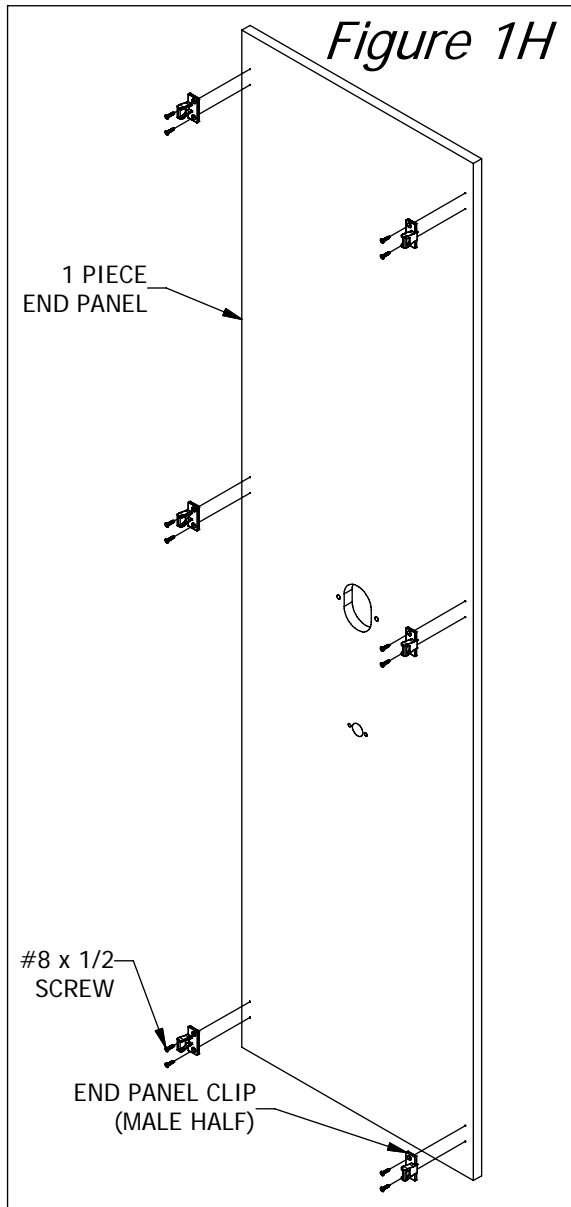

MobileTrak5 Mechanical End Panel Installation Instructions

INSTALLING T-HANDLE

Install T-handle to end panel by inserting threaded portion through hole in end panel (see Figure 1K). On 3 piece end panels, handle hole is located on bottom panel. On 1 piece end panels handle hole is lower hole on panel. Attach to wood panel with #8-32 x 7/8" machine screw. Attach to steel end panel with #8-32 x 3/8" machine screws. Screw first 3/8 jam nut on to T-handle. Place lock cam on handle shaft as shown in Figure 1J. Finger tighten second jam nut onto handle shaft. Distance cam 1/8" from end of handle shaft (see Figure 1L). Fully tighten jam nuts.

INSTALLING END PANELS

If using steel end panels, attach steel panel spacers to drive tower using (4) #8 x 3/8 Tek screws (see Figure 1M). On all panels, align T-handle and chain lock bar according to instructions on Page 18. Align male clips on end panel with female clips on uprights. Using smooth, firm pressure, press end panels onto uprights. Tighten (2) 1/4-20 x 1" hex bolts through holes next to crank shaft.

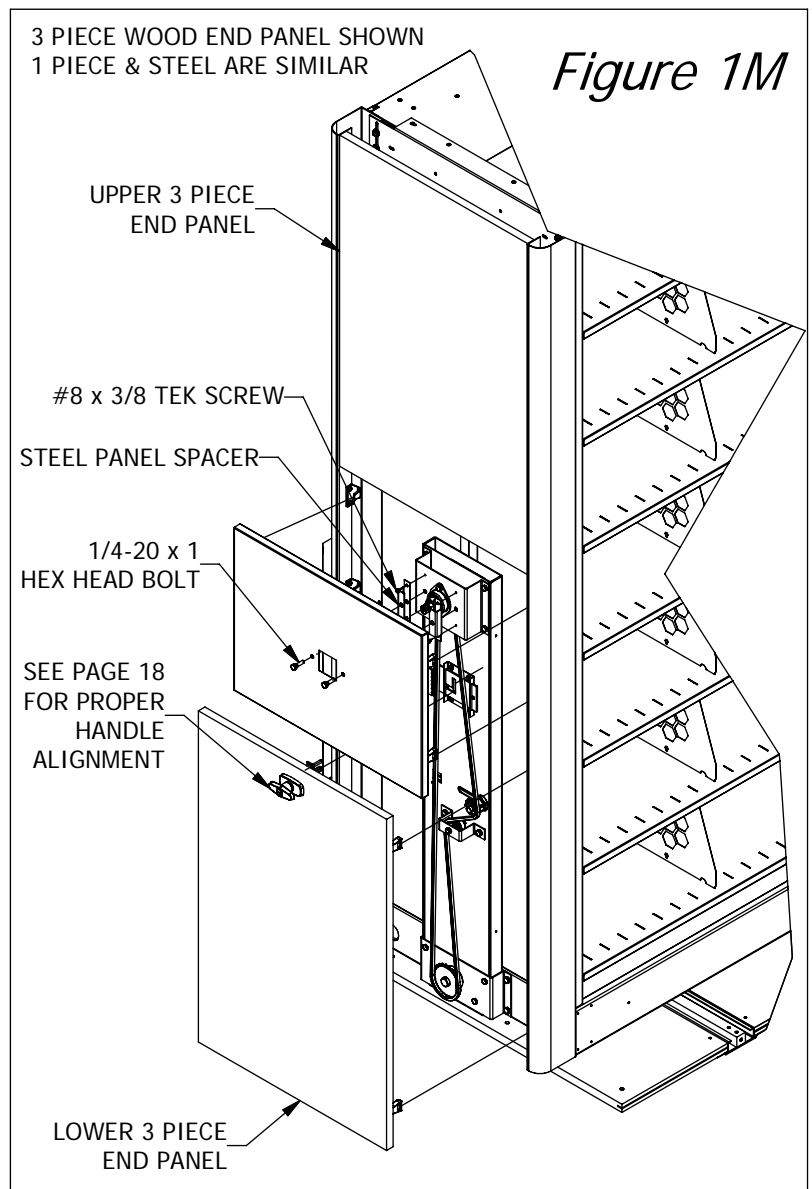
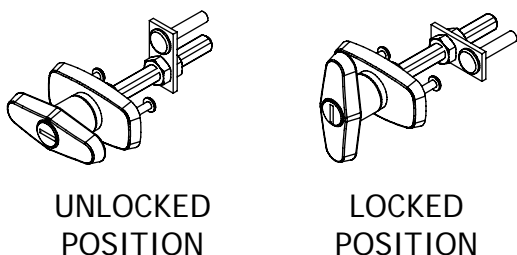
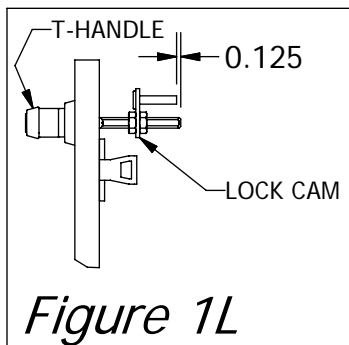
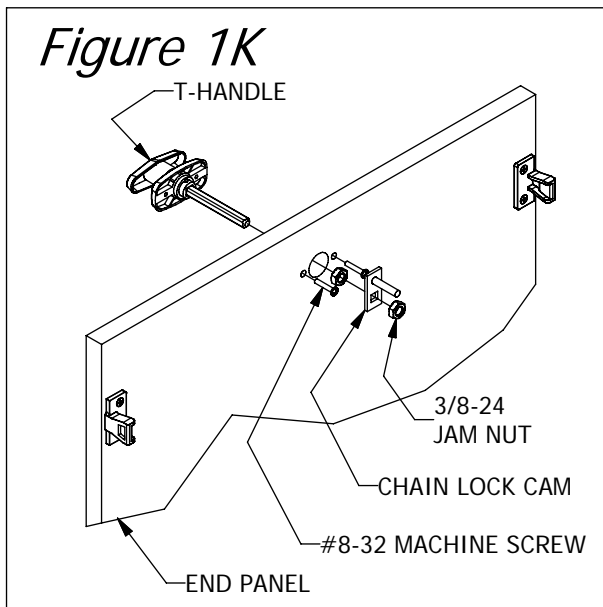

MobileTrak5 Crank Installation Instructions

Figure 1N

HANDLE AND HUB INSTALLATION

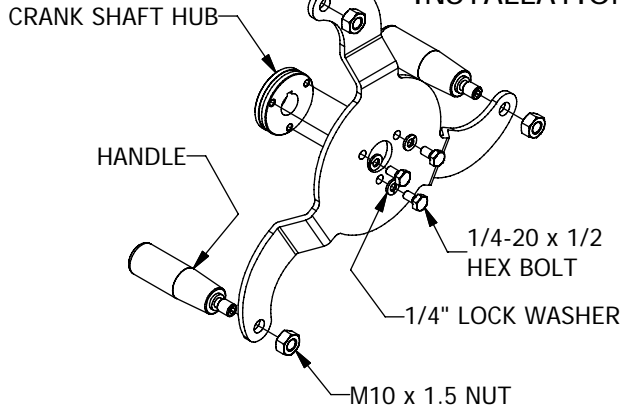

3 SPOKE WITH STANDARD HANDLE SHOWN
OTHERS ARE SIMILAR

Align 3 crank shaft hub holes with 3 holes in crank. Install 1/4-20 x 1/2" hex bolts with 1/4" lock washers through crank, into crank shaft hub (see Figure 1M). Place handle/ knob into crank and tighten with M10 x 1.5 nuts.

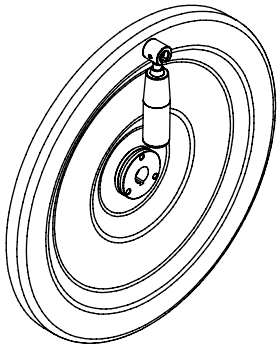

CRANK DISC
SHOWN W/ FOLDING HANDLE

Place key in slot on crank shaft. Slide crank assembly onto crank shaft, aligning hub slot with key on shaft (see Figure 1N). Tighten crank onto shaft using 5/16-18 x 5/8" flanged bolt and 5/16 wide flat washer. Place hex hub cover over crank shaft hub.

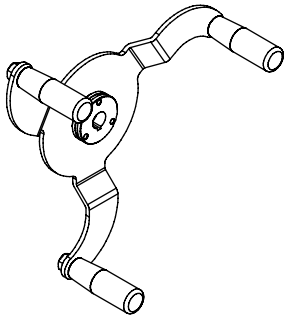

3 SPOKE CRANK
SHOWN W/ STANDARD HANDLE

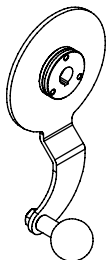

1 SPOKE CRANK
SHOWN W/ BALL KNOB

3 SPOKE SHOWN
OTHERS ARE SIMILAR

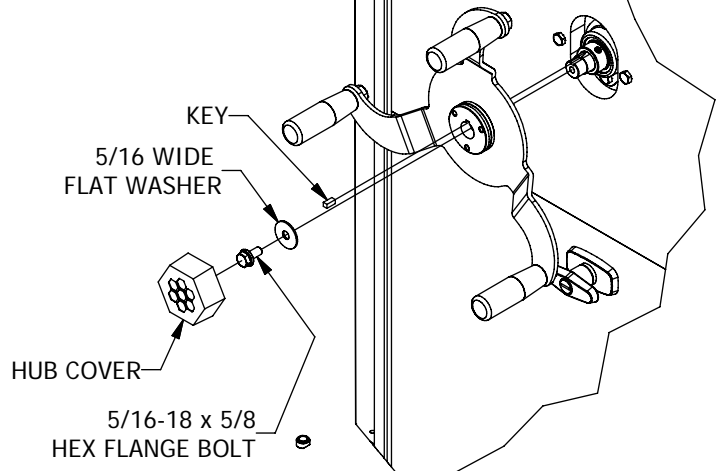
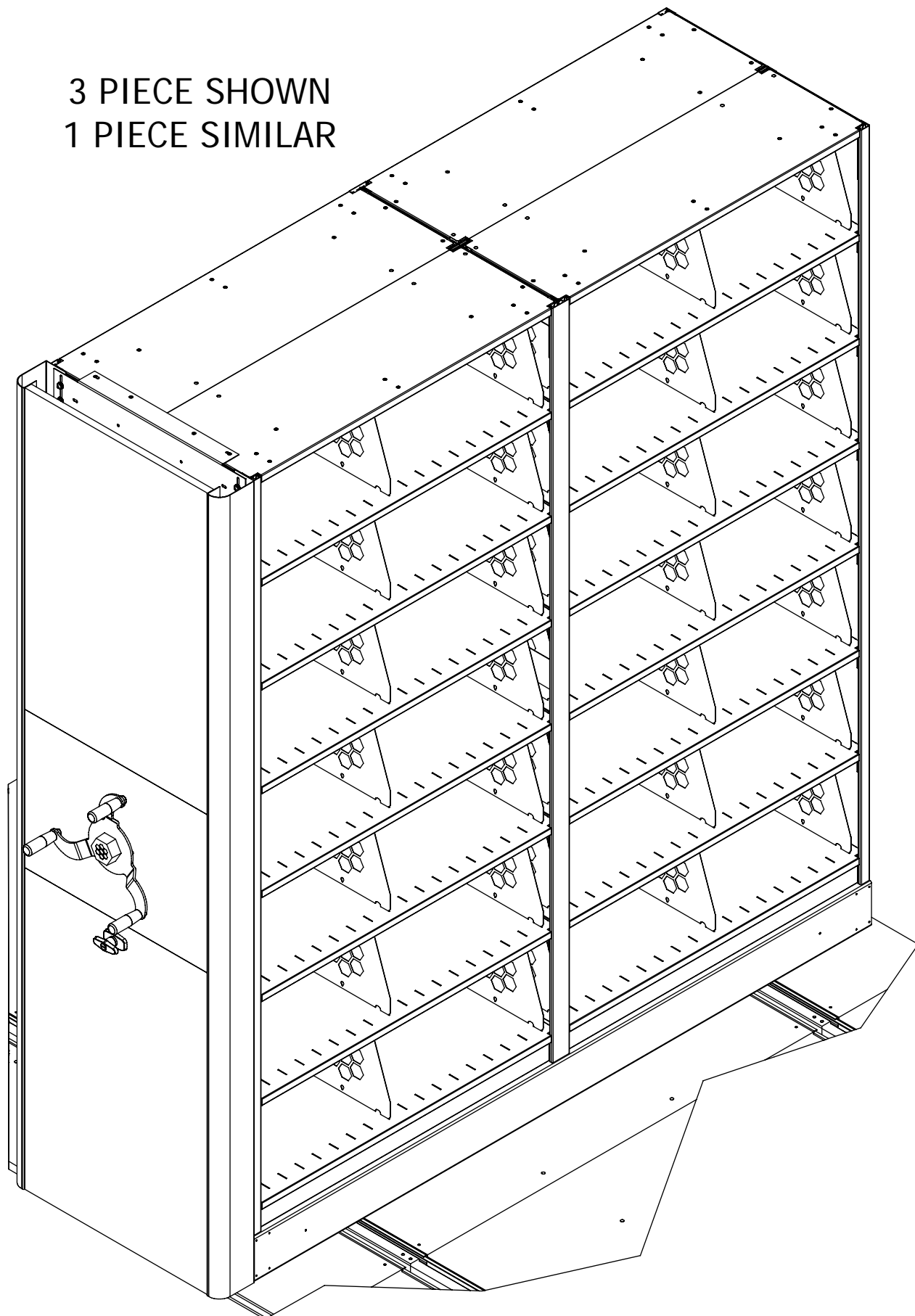

Figure 1O

MobilTrak5 Completed Mechanical End Panel

3 PIECE SHOWN
1 PIECE SIMILAR



**THIS PAGE
INTENTIONALLY
LEFT BLANK**

MobileTrak5 Manual End Panel Installation Instructions

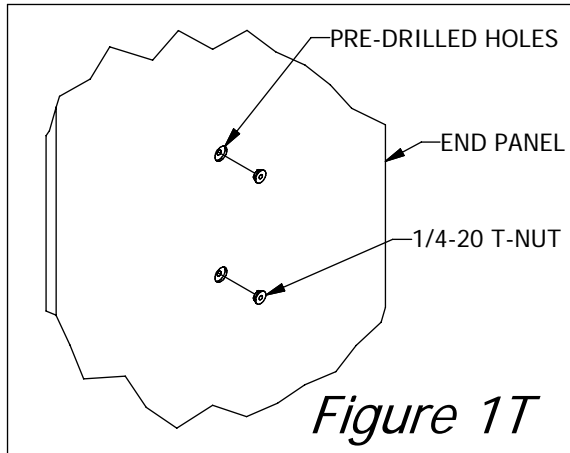
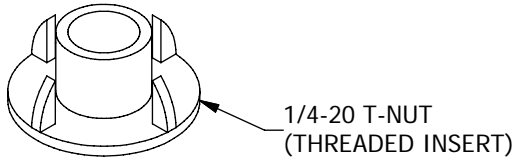

Before mounting end panel to shelving make sure that the pre-drilled holes (for pull handle) have the threaded inserts (T-nuts) in them (see Figure 1T). Place end panel against shelving being sure bottom of end panel is flush with bottom of carriage. With someone holding panel in place, drill through shelving and into the back side of the laminated panel (see Figures 1U & 1V). DO NOT DRILL COMPLETELY THROUGH LAMINATED END PANEL. Use #8 x 1/2" wood screws to attach panel to shelving. End panel should be attached with a minimum of eight screws. Repeat step for remaining carriages.

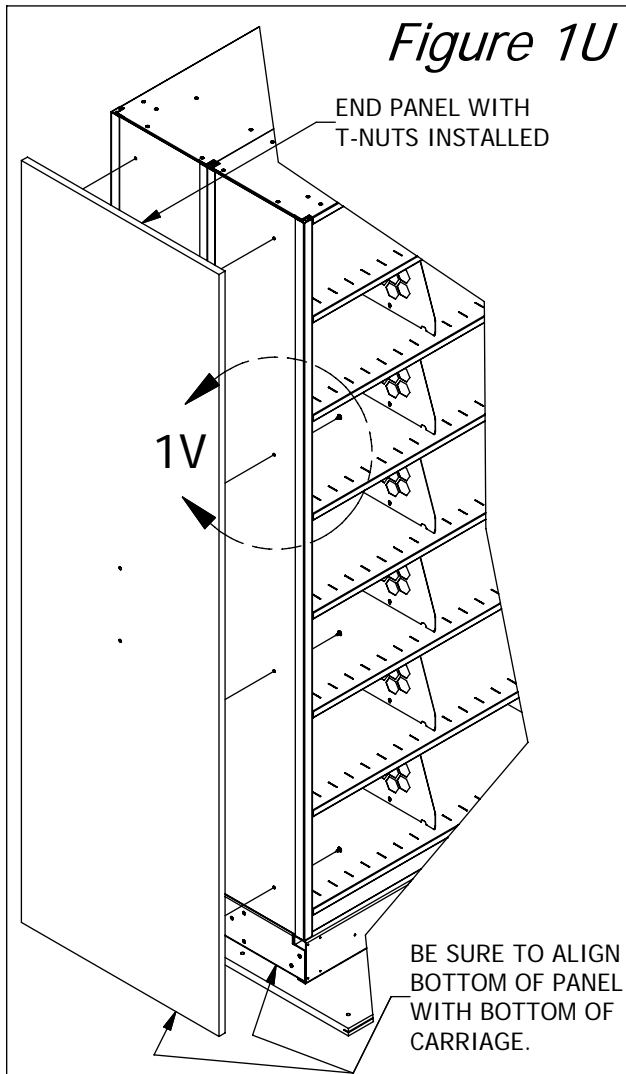
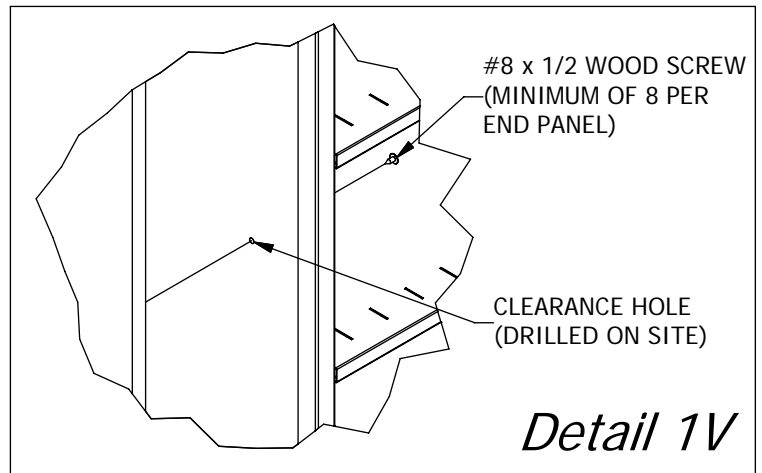

Attach pull handles using 1/4-20 x 1" Allen cap screws and 1/4-20 T-nuts (for laminated end panels), see figure 1W or 1/4-20 flanged hex nuts (for attaching directly to shelving).

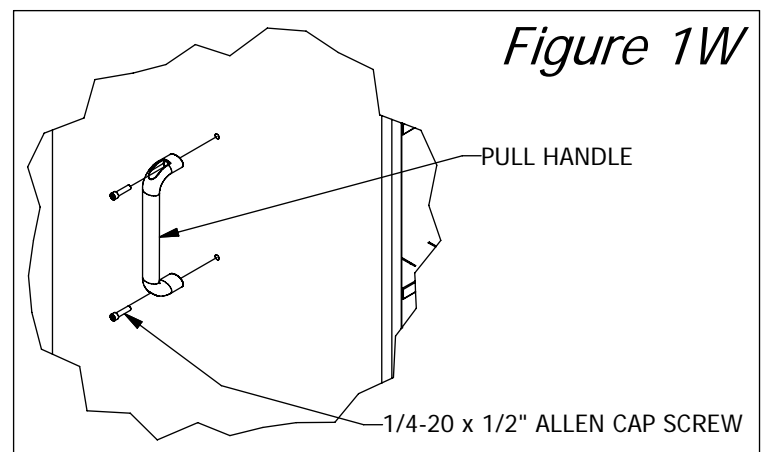

MobileTrak5 Rear Panel Installation Instructions

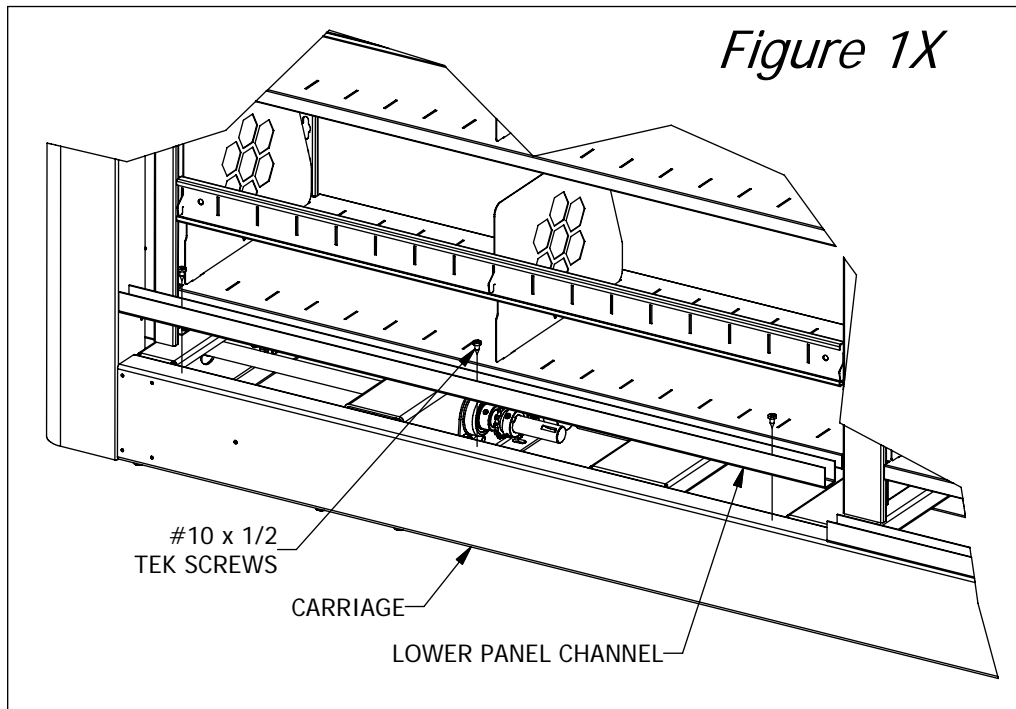

Attach lower channels to the carriage using #10 x 1/2 Tek screws (see Figure 1X). NOTE: Channels are manufactured 1/8" shorter than the width of the shelving it's covering (ex. 36" wide shelving will have 35 7/8" long channels), so space channels accordingly.

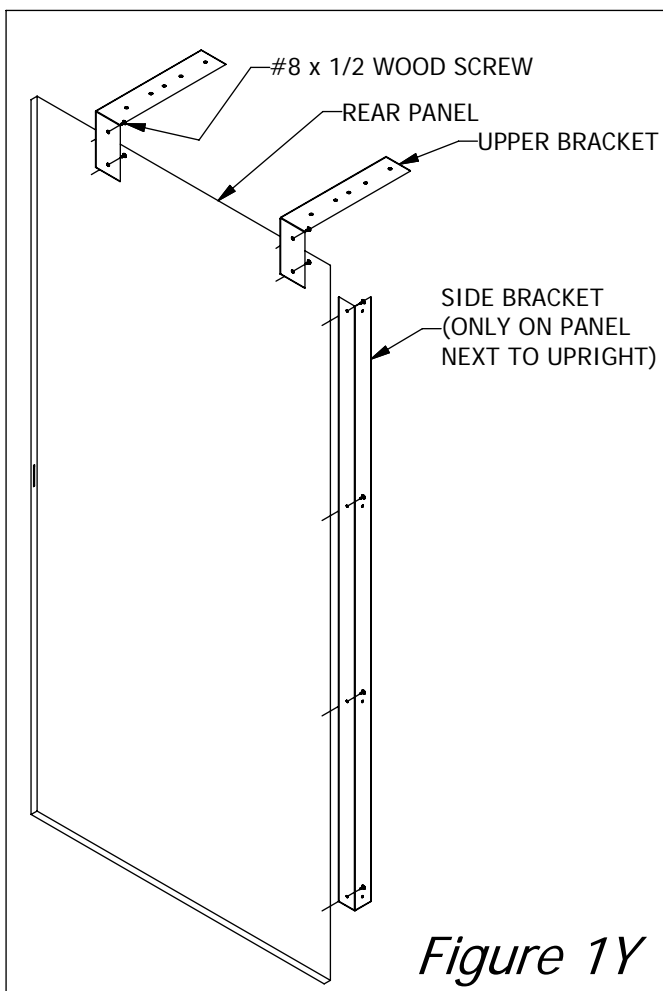

Attach the side bracket to one of the rear panels using four #8 x 1/2" wood screws (see Figure 1Y). Position the bracket on the edge of the panel and center vertically.

On the same panel, attach two upper brackets to the top of the panel using #8 x 1/2" wood screws (two per bracket).

MobileTrak5 Rear Panel Installation Instructions

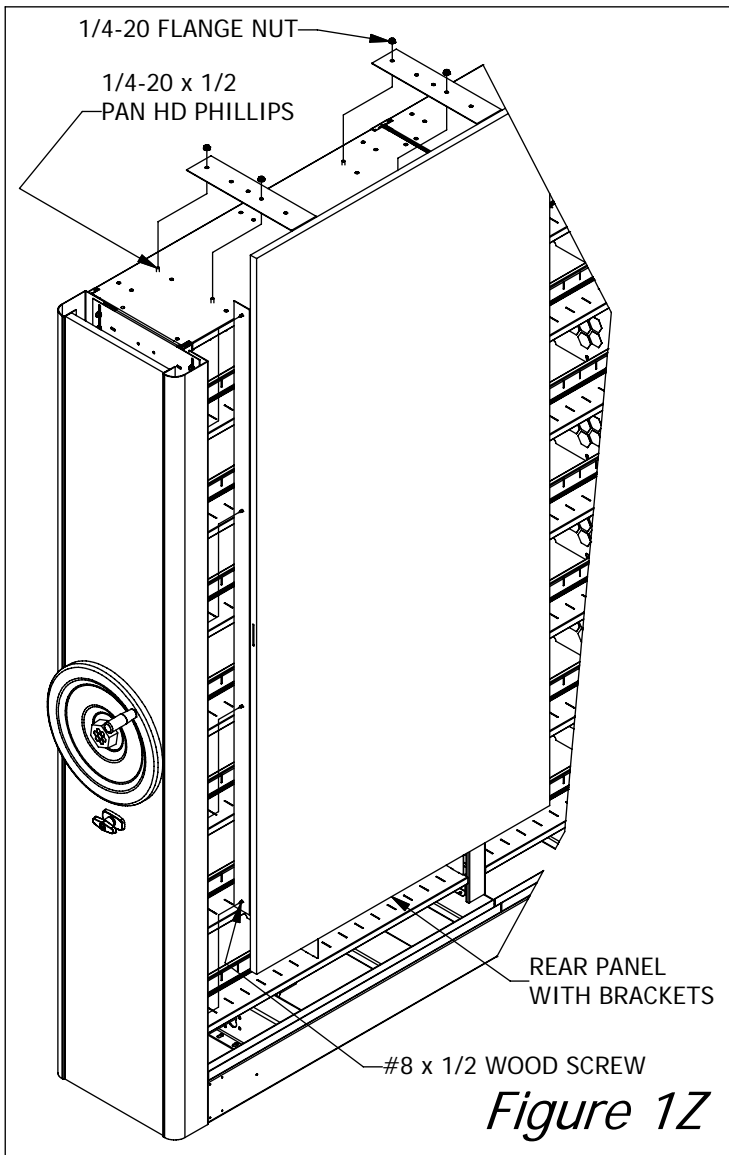

Figure 1Z

If the the system is equipped with Datum ThinStak style shelving, the top cover will have knockouts in it to align with the holes in the upper brackets (see Figure 2A). If any shelving other than Datum Thinstak shelving is being used, holes will need to be drilled into the top of the shelving. Four 1/4-20 x 1/2" pan head Phillips screws and flanged nuts are supplied to attach upper brackets to shelving (see Figure 1Z).

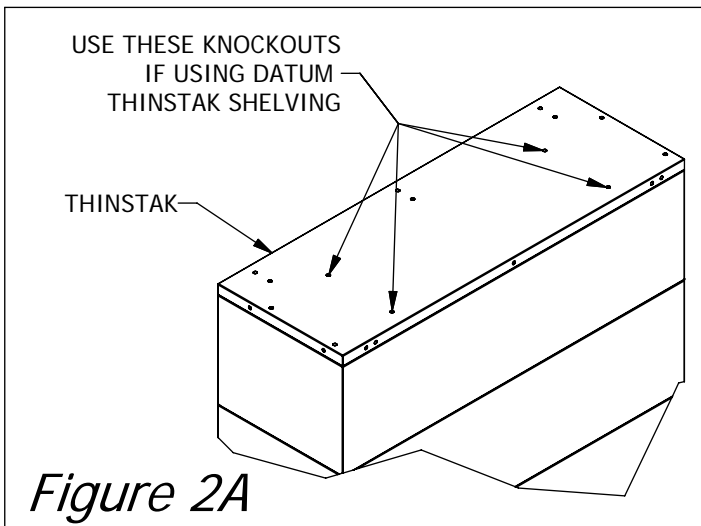
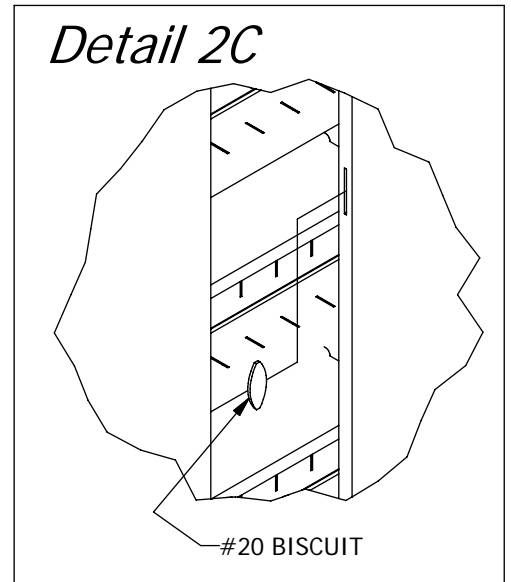
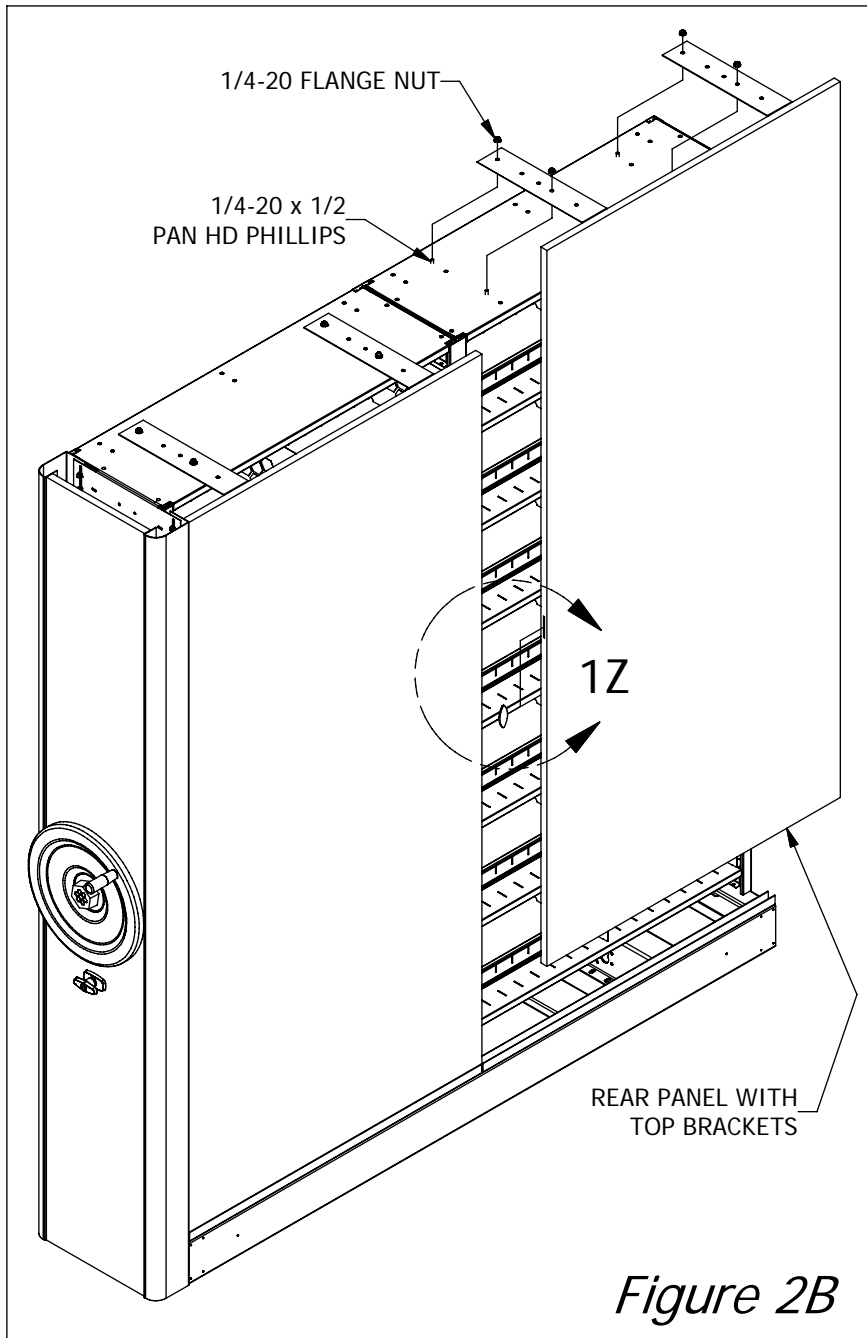

Figure 2A

MobileTrak5 Additional Rear Panel Installation Instructions

Insert a wooden biscuit joint into the rear panel that was just installed (see Detail 2C). Slide the next rear panel into the lower channel and align the biscuit joint with the hole in the side of the panel (see Figure 2B). Attach another set of upper brackets to the rear panel. If the system is equipped with Datum ThinStak style shelving, the top cover will have knockouts in it to align with the holes in upper brackets. If any shelving other than Datum ThinStak shelving is being used, holes will need to be drilled into the top of shelving. 1/4-20 x 1/2" pan head phillips screws and flange nuts are supplied to attach upper brackets to shelving (four per shelf). Repeat for remaining panels.



MobileTrak5 Installation Instructions

If you need assembly assistance, please contact Customer Service at:
1-866-217-0330 (Monday through Friday 8:00 A.M. - 5:00 P.M. E.S.T.)