



SNYDER



Equipment, Inc.

Storing, Rolling, Lifting since 1947

PRODUCT INFORMATION

Digilock electronic locks for lockers

2946 Larimer St. Denver, CO 80205
303-295-1100 / 800-373-7693
FAX 303-295-2464
Email info@snyderequipment.com
www.snyderequipment.com



STYLE - CONVENIENCE - FREEDOM

DIGILOCK'S UNIQUE FEATURES AND UNSURPASSED QUALITY BRING STYLE AND CONVENIENCE INTO YOUR LOCKER ROOM WHILE ENHANCING YOUR MEMBERS' EXPERIENCE. WITH DIGILOCK YOUR MEMBERS WILL BE FREE OF KEYS AND YOU WILL BE FREE OF LOCKER MANAGEMENT.

ELECTRONIC MANAGEMENT ACCESS

DIGILOCK PROVIDES KEYLESS LOCKS FOR BOTH SHARED AND ASSIGNED USE LOCKERS. USERS ACCESS THEIR BELONGINGS WITH A FOUR-DIGIT SELF SELECTED CODE AND MANAGEMENT ACCESS IS PROVIDED WITH UNIQUE ELECTRONIC BYPASS KEYS THAT ELIMINATE THE COMPROMISING OF THE MANAGEMENT CODE WHILE MINIMIZING THE TIME SPENT PROGRAMMING AND REPROGRAMMING MANAGEMENT ACCESS TO EACH LOCK.

SHARED USE LOCKS

Digilock shared use locks are designed for lockers that are shared by multiple users throughout the day. Users lock and unlock any available locker with a self selected four-digit code while management has access with a manager bypass key. When unlocked, Digilock shared use locks will remain unlocked until locked by another user. Digilock is equipped with a 1/2" deadbolt preventing and guarding against break-ins. Other product features include a usage indicator, a low battery indicator, tamper guard and a programmable automatic unlock. Also available with audit trail and/or card activation.

ASSIGNED USE LOCKS

Digilock assigned use locks are designed for lockers that are rented or assigned to a specific user. Users access their locker with a four-digit programmable user code while management has access with a manager bypass key. Digilock is equipped with a 1/2" deadlatch preventing and guarding against break-ins. Other product features include a low battery indicator and tamper guard. Also available with audit trail.





MANAGER BYPASS KEY

The manager bypass key is the all-in-one tool for management. A simple touch of this key to the key slot provides lock access and will also provide external power to the lock in case of battery failure. (Anticipated battery life is 3-5 years depending on model and usage). A programming key registers up to 25 manager bypass keys to each lock.



ADA USER KEY

Digilock is ADA compliant. Club members with disabilities are issued an ADA User Key that replaces the code and allows access to any available locker without tight grasping, tight pinching or twisting of the wrist.





5341 OLD REDWOOD HWY • SUITE 200
PETALUMA • CALIFORNIA 94954 • USA

PHONE: 707. 766.6000

FAX: 707. 766.6226

E-MAIL: SALES@DIGILOCK.COM

WWW.DIGILOCK.COM



ilock[®]

by : SECURITY PEOPLE INC

DRILL TEMPLATE

2

Using a pencil, mark the door edge on the template and also mark the centerline on the door edge. Open door, remove template.

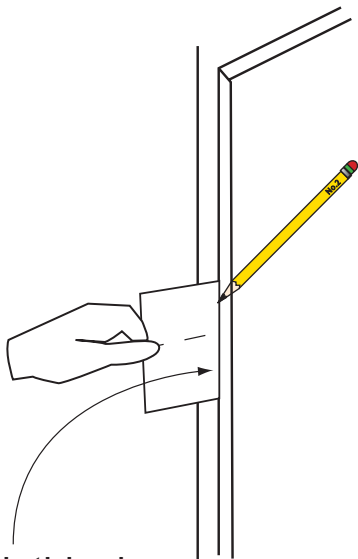

Mark this door edge on the paper template

1

Center the template over the strike plate and align edge of strike plate with the line on template, and close door while holding the template in place

Strike Plate

Edge of Strike Plate

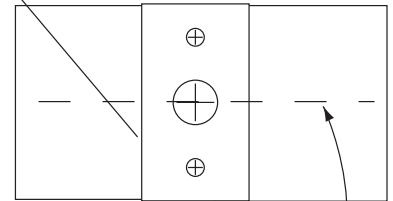

Centerline

3

Place the template over the door aligning it with the centerline on the template and the centerline mark you made on the door edges as well as aligning the door edge with the door edge you made on the template.

Mark the centers of all three holes and drill the holes as defined on the template.

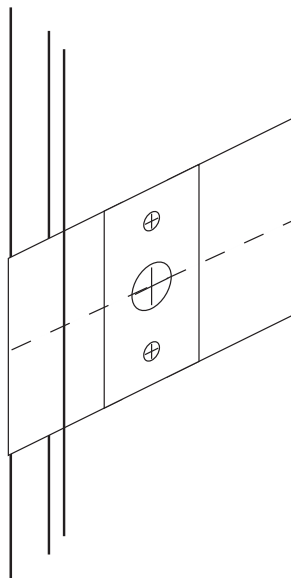

Digilock®

by : SECURITY PEOPLE INC

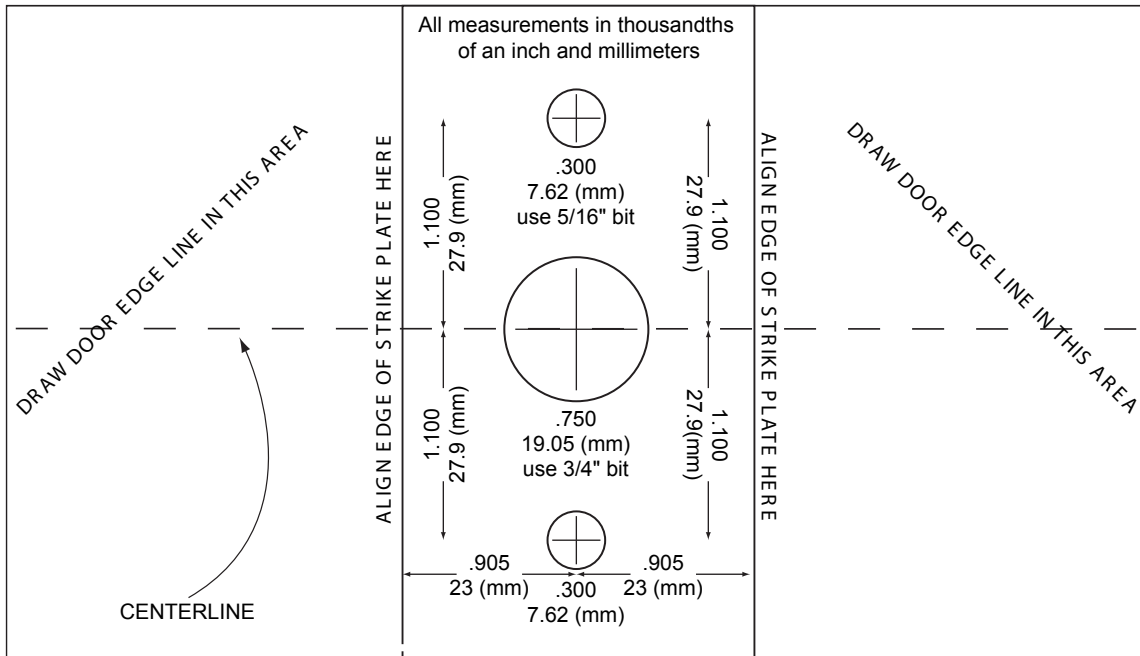

***NOTE: FILE MAY NOT PRINT TO SCALE.
DOUBLE CHECK ALL MEASUREMENTS BEFORE DRILLING DOOR.**

