

# SNYDER



**Equipment, Inc.**

*Storing, Rolling, Lifting since 1947*

**PRODUCT INFORMATION**

## **DERO BIKE RACKS**

2946 Larimer St. Denver, CO 80205  
303-295-1100 / 800-373-7693  
FAX 303-295-2464  
Email [info@snyderequipment.com](mailto:info@snyderequipment.com)  
[www.snyderequipment.com](http://www.snyderequipment.com)

# S w e r v e R a c k

- Architectural Design
- High security, thick tube construction
- Uses space efficiently
- In-ground, surface, and rail-mounted models

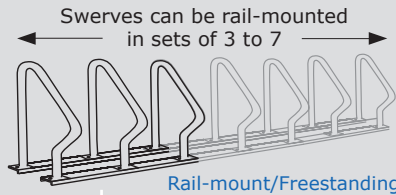
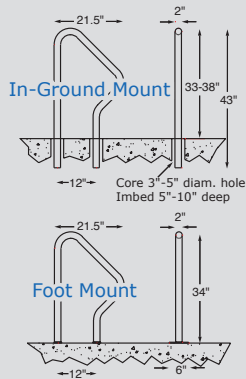

Product #	Finish Options	Mount Options
SW	GV, EPX, ST	IG, FT, FS

(See Back page for description of product codes)

# B i k e H i t c h

- Simple, clean design
- High security
- Thick pipe construction
- Designed for sidewalk placement
- In-ground and surface mounted models available

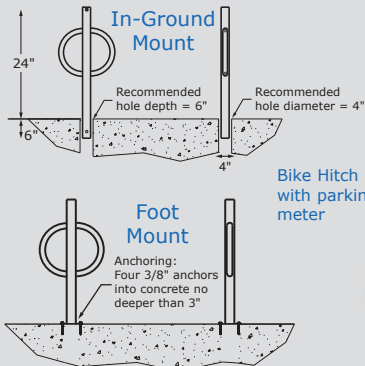

Bike Hitch with parking meter



Product #	Finish Options	Mount Options
BH	GV, EPX, ST	IG, FT

(See Back page for description of product codes)

# S p a c e S a v e r



- Doubles your parking capacity
- Perfect for Bike Rooms
- Most space efficient rack
- Modular construction: can fit any space
- Surface-mounted, Free-standing or wall-mounted models available
- Easy installation
- High security: fully U-lock compatible
- Single and double sided models available
- Soft polycoating on 3/8" hanger rods

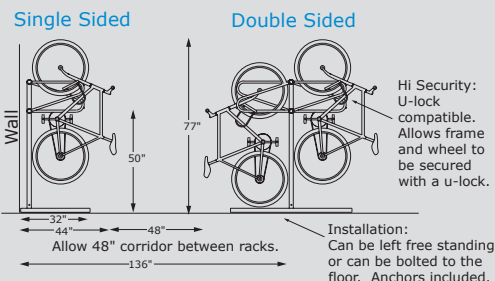

Product #	Finish Options	Mount Options
SS-S=Single SS-D=Double	EPX	FT, FS, Wall

When Specifying, indicate # of bikes to park



# Campus Rack



- High security
- Design ensures orderly parking
- Single or double sided models
- Single-sided model ensures parking on only one side (keeps sidewalks clear)

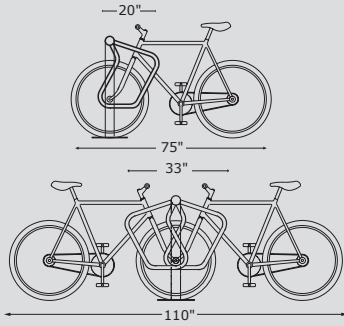

## Campus Rack Configurations

<b>Single</b>	Model #: S-3 Bikes Parked: 5
	Model #: S-5 Bikes Parked: 7
	Model #: S-6 Bikes Parked: 8
<b>Double</b>	Model #: D-5 Bikes Parked: 7
	Model #: D-7 Bikes Parked: 9
	Model #: D-11 Bikes Parked: 13



Product #	Finish Options	Mount Options
S-3 thru D-11	GV, EPX, ST	FT, FS

(See Back page for description of product codes)

# Rolling Rack



- Attractive design
- Accommodates single and double sided parking
- In-ground, surface, and free-standing models
- Different sizes available
- Material: 2.375" OD Sched. 40 pipe construction

	2H 36" 5 Bikes
	3H 60" 7 Bikes
	4H 84" 9 Bikes
	5H 110" 11 Bikes



Product #	Finish Options	Mount Options
RR2H-RR5H	GV, EPX, ST	IG, FT, FS

# Bike Bike Rack



- Makes a bold statement about bike transportation
- Attractive design
- High security
- Easy installation
- One unit parks 2-4 bikes

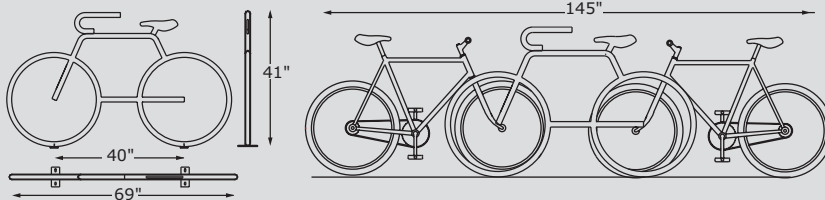

Product #	Finish Options	Mount Options
BB	GV, EPX, ST	FT, FS

# Hoop Rack



- High security
- In-ground, surface and free-standing models available



Product #	Finish Options	Mount Options
BH	GV, EPX, ST	IG, FT

# Helix Rack



- Graceful design
- Easy to install
- Superior bike support

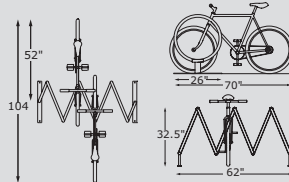

Product #	Finish Options	Mount Options
HX	GV, EPX, ST	FT

# Double Decker



Contact us for more information

# Wall Rack



Contact us for more information

# Alley Rack



Contact us for more information

# Finish Options

## TGIC Powdercoated finish (EPX)

We offer over 250 high quality TGIC powder coated colors and specialize in matching color schemes. Our powdercoat finish starts with a sandblast treatment which cleans and etches the steel surface. The racks are then scrubbed and given an iron phosphate pretreatment. An epoxy primer is electro-statically applied to ensure excellent adhesion to the base steel and to provide a hard shell that will protect the steel against corrosion and scratches. A final TGIC powdercoat is electro-statically applied and baked on to give the rack the final color and an additional layer of protection.

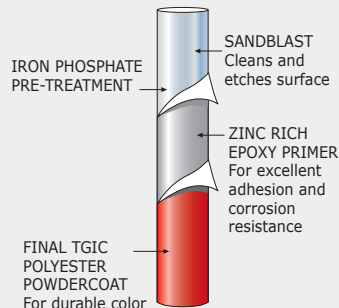

## Hot Dipped Galvanized (GV)

Hot dipped galvanized is an extremely durable and low cost finish option. All of our products are hot-dipped galvanized after fabrication and then hand ground to ensure a clean, safe surface. Unless otherwise noted, a hot dipped galvanized finish is included standard in the cost of all Dero products. We suggest using galvanized or stainless steel in locations where snow removal and corrosion are an issue.

## Stainless Steel (ST)

Stainless steel is the most beautiful and durable option. We use a 304 grade stainless steel which will continue to look brand new and attractive for years.

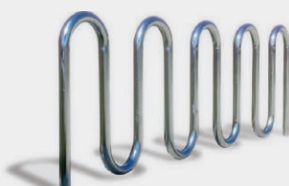

# Mounting Options

## Surface Mount (FT)

Foot plate is anchored to concrete surface with masonry anchors

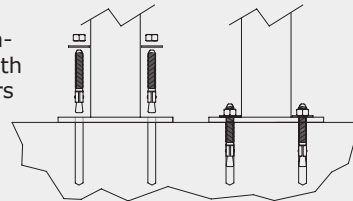

## In-Ground Mount (IG)

Foot is embedded below concrete surface.

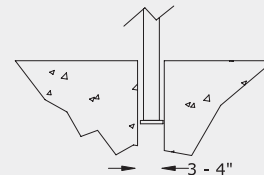

## Free-standing Mount (FS)

Rack can be bolted down or left free-standing. Ideal for installation on to pavers or other sensitive base materials.

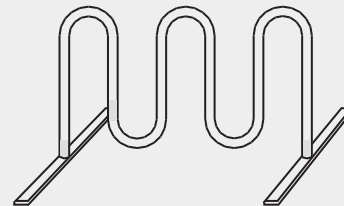

# Sample Order

SW - EPX - FT = Swerve Rack  
Product #    ↑    Powdercoated finish  
Finish        ↑    (Specify color, i.e. Hunter Green, etc.)  
Mount         ↑    Surface Mounted  
 Please specify quantity